

# **Service Manual**

---

instructions  
for  
servicing  
Necchi  
sewing  
machines

**NECCHI**

VITTORIO NECCHI s. p. a. PAVIA (Italy)

# Service Manual

---

instructions  
for  
servicing  
Necchi  
sewing  
machines

**NECCHI**

VITTORIO NECCHI s. p. a. PAVIA (Italy)

## GENERAL INDEX

INSTRUCTIONS FOR SERVICING NECCHI SEWING MACHINES . . . . .	page	1
<i>Tools and necessary accessories</i> . . . . .	»	4
<i>Instructions to be given to the customer</i> . . . . .	»	5
1. Using the correct needle . . . . .	»	5
2. Correct threading of the BF and BU Mira machines . . . . .	»	6
3. Correct threading of the BF and BU Nova machines . . . . .	»	8
4. Cleaning the shuttle race . . . . .	»	8
5. Adjusting the thread tensions . . . . .	»	12
ELEMENTARY INSTRUCTIONS ON MACHINE MAINTENANCE . . . . .	»	13
1. Cleaning . . . . .	»	13
2. Lubrication . . . . .	»	13
3. General remarks . . . . .	»	14
TECHNICAL CHARACTERISTICS OF NECCHI SEWING MACHINES . . . . .	»	14
ADJUSTING THE MOVEMENTS OF THE VARIOUS GROUPS OF PARTS IN RELATION TO EACH OTHER (TIMING THE MACHINE) . . . . .	»	15
TIMING OF SHUTTLE AND NEEDLE BAR IN THE BF NOVA AND BF MIRA MACHINES . . . . .	»	17
I <i>Adjustment</i> - height of the needle bar . . . . .	»	17
1. Insertion of the timing gauge No. AC 4/75 . . . . .	»	17
2. Timing procedure . . . . .	»	19
II <i>Adjustment</i> - distance between the needle and the shuttle . . . . .	»	19
III <i>Adjustment</i> - centering the needle in relation to the race cover plate . . . . .	»	20

IV	<i>Adjustment</i> - position of the needle eye in relation to the shuttle . . . . .	page 20
	<b>TIMING OF SHUTTLE AND NEEDLE BAR IN THE BU NOVA AND BU MIRA MACHINES</b> . . . . .	» 22
I	<i>Adjustment</i> - height of the needle bar . . . . .	» 22
II	<i>Adjustment</i> - position of the needle eye in relation to the shuttle . . . . .	» 22
III	<i>Adjustment</i> - distance between the needle and the shuttle . . . . .	» 24
IV	<i>Adjustment</i> - centering the needle in relation to the race cover plate . . . . .	» 24
1.	Insertion of the timing gauge No. AC 4/68 and of the square-angled bar E . . . . .	» 26
2.	Timing procedure . . . . .	» 26
3.	To remove the gauge AC 4/68 . . . . .	» 27
	<b>IMPORTANT - ADJUSTMENT OF THE SHUTTLE CARRIER SHAFT IN BF AND BU MACHINES</b> . . . . .	» 28
	<b>TIMING OF FEED DOG AND NEEDLE BAR - GENERAL RULE</b> . . . . .	» 31
	<b>TIMING THE ZIG-ZAG MECHANISM AND THE NEEDLE BAR (FOR BU MACHINES ONLY) - GENERAL RULE</b> . . . . .	» 34
	Timing procedure . . . . .	» 36
	The feed dog . . . . .	» 37
	<b>ADJUSTING THE MAXIMUM RISE OF THE FEED DOG TEETH ABOVE THE NEEDLE PLATE - GENERAL RULE</b> . . . . .	» 39
RE. 1.	Incorrect pressure of the presser foot . . . . .	» 41
RE. 2.	Bottom face of the presser foot rests incorrectly (not flush) on the teeth of the feed dog . . . . .	» 41
	<b>TESTING THE FEED DOG</b> . . . . .	» 43

THE NEEDLE BAR . . . . .	page 44
THE NEEDLE OF THE MACHINE . . . . .	» 44
PRESSURE ADJUSTMENT OF THE PRESSER FOOT . . . . .	» 46
POSITIONING OF PRESSER BAR AND PRESSER FOOT . . . . .	» 47
Height of presser foot . . . . .	» 48
1. The presser bar lever is entirely down . . . . .	» 48
2. The presser bar lever is partially raised . . . . .	» 48
3. The presser bar lever is completely raised . . . . .	» 48
TENSION OF THE UPPER THREAD . . . . .	» 49
The thread take-up spring (check spring) of the upper tension . . . . .	» 50
TENSION OF THE LOWER THREAD (TENSION OF THE BOBBIN CASE) . . . . .	» 52
THE OSCILLATING SHUTTLE . . . . .	» 52
THE BOBBIN CASE . . . . .	» 55
THE BOBBIN . . . . .	» 55
THE STITCH REGULATOR . . . . .	» 56
1. The stitch regulating indicators do not move . . . . .	» 57
2. The length of stitch during forward sewing is not the same as that during reverse sewing . . . . .	» 59
THE BOBBIN WINDER MECHANISM (FOR BF AND BU MACHINES) . . . . .	» 59
THE ZIG-ZAG STITCH MECHANISM . . . . .	» 62
Upper group of the zig-zag mechanism . . . . .	» 64
Adjusting the upper group of the zig-zag mechanism . . . . .	» 75
The lower group of the zig-zag mechanism . . . . .	» 75

TAKING CARE OF THE SEWING MACHINE MOTOR	page 77
A. Motor does not run at all or runs sluggishly . . . . .	» 77
B. Motor turns tightly . . . . .	» 77
C. Motor runs, but does not pull the machine . . . . .	» 78
D. Motor is weak . . . . .	» 78
E. Motor gets too hot . . . . .	» 79
F. Motor smokes or emits a burning smell . . . . .	» 79
G. Motor runs noisily or growls. Rattling noise during sewing . . . . .	» 79
How to remove the machine head . . . . .	» 80

## INSTRUCTIONS FOR SERVICING NECCHI SEWING MACHINES

This service manual shall be used together with the instructions books for the BF Nova and Mira and BU Nova and Mira Sewing Machines and with the parts catalogue for these machines.

The maintenance of the NECCHI Sewing Machines requires no special skill or knowledge. All that is needed is a certain mechanical aptitude and the availability of the necessary tools. This manual is intended only for those mechanics who make routine repairs and replace single defective parts. Major repairs should not be carried out by persons of limited experience. Therefore, if major repairs are required, it is suggested that the complete head be returned to the distributor, after prior authorization has been received from that distributor.

The NECCHI Sewing Machines, like practically all sewing machines designed for household use, work on the principle of the Lockstitch. This type of stitch is obtained by interlocking the upper and lower thread inside of the fabric, while the needle, going down to its lowest position, penetrates the fabric and rises again to its highest position. The two threads of the seam are thus tightly interlocked at every stitch, adhere closely to the fabric and hold the plies of the fabric firmly together. If either of the two threads breaks, or if the threads are cut off after the sewing operation is completed, the seam will not unravel, but only two or three stitches may get loose and open up. The illustrations, Figures 1 to 4, indicate the formation of a single lockstitch and the interlocking of both threads in the fabric.

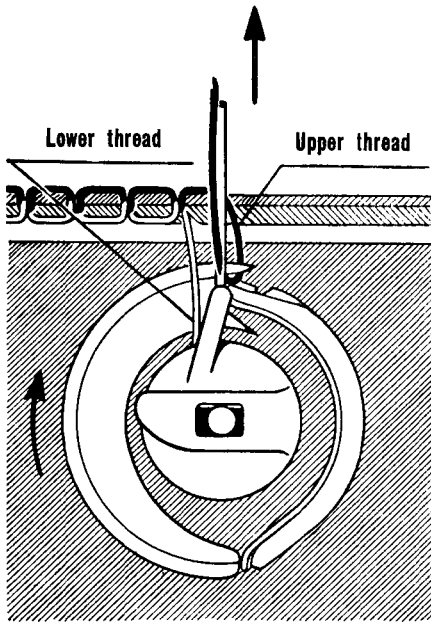

Fig. 1

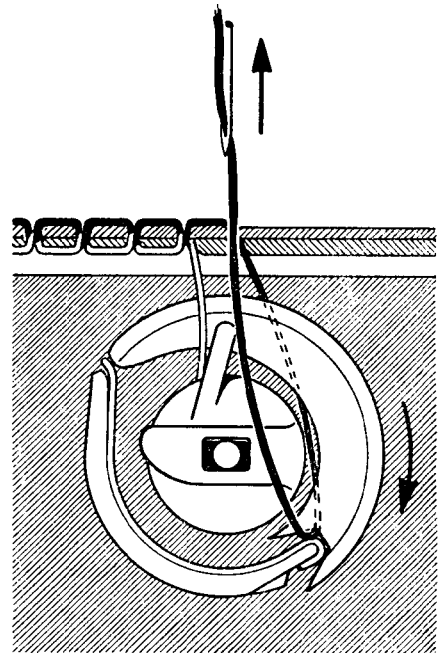

Fig. 2

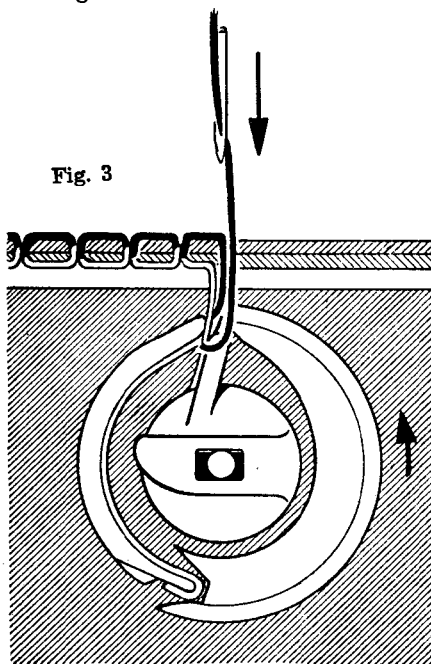

Fig. 3

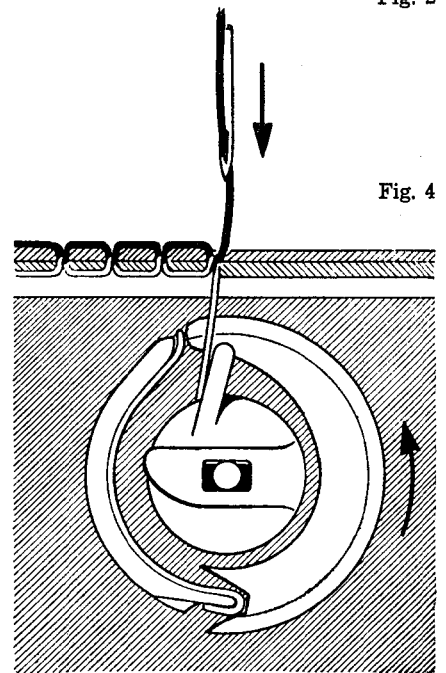

Fig. 4



All machines consist of two major portions, the arm and the bed. Arm and bed are firmly held together by means of screws and pins. In the horizontal portion of the arm is inserted the arm shaft (upper shaft) which obtains its rotary movement from the revolving balance wheel. The balance wheel, which is securely fastened to the right hand end of the arm shaft, is driven by a belt from an electric motor. The various movable parts of the sewing machine obtain their respective movements from the rotary of the arm shaft with the aid of connecting rods, cranks, levers, etc. Below the bed of the machine is mounted the oscillating shaft (driver shaft), to the left end of which is firmly attached the shuttle carrier. By means of a crank connecting rod, and oscillating rock shaft, a slide block and a shaft crank, the rotary movement of the arm shaft is transformed into the oscillating movement of the carrier shaft. The shuttle carrier, in turn, imparts the oscillating movement to the oscillating shuttle which moves back and forth inside of the shuttle race. The forward and backward, as well as the up and down movements of the feed dog, are also obtained from the rotary movement of the arm shaft by means of connecting rods, rock shafts and a feed bar below the bed of the machine.

The up and down movement of the needle bar, as well as that of the thread take-up lever, is also derived from the rotary movement of the arm shaft by means of cranks and a connecting link.

The bobbin case is placed on the post inside of the oscillating shuttle and then pressed into the oscillating shuttle. The oscillating shuttle, after its point has entered the loop of the needle thread, makes a partial revolution, just sufficient to carry the enlarged loop of the needle thread over and around the bobbin case and then lets it slide off easily from the oscillating shuttle. After the rising thread take-up lever has pulled the needle thread away from the oscillating shuttle, the shuttle returns to its starting position. This oscillating movement of the shuttle is repeated at every stitch.

To the arm of the machine are also attached the tension mechanism for the needle thread (upper tension), furthermore the various thread guides which lead the thread from the spool to the needle.

### Tools and necessary accessories

To service and repair any type of sewing machine efficiently, the mechanic should have available proper tools and several accessories, essential for a good maintenance job. He must know how to operate the machine and be familiar with the various mechanisms of the machine and the manner in which they are adjusted (timed). Finally, he must be scrupulous about cleaning the machine and oiling all the parts which require lubrication.

The following tools and accessories should be at the mechanic's disposal:

1. A set of two or three good screw drivers with various lengths and widths of the blades.
2. A small screw driver for adjusting the tension spring on the bobbin case.
3. An adjustable small wrench.
4. A light hammer.
5. A pair of medium-sized flat-nosed pliers.
6. A container of cleaning fluid (kerosene).
7. A container (oil can) of good light sewing machine oil (NECCHI oil).
8. Two tin pans (for cleaning fluid and lubrication oil), large enough to hold various small machine parts.
9. A small brush (paint brush) for cleaning.
10. A sharp-pointed pin (long heavy needle) for removing lint and dirt.
11. Emery cloth (medium and fine).
12. Emery cord.
13. Soft cleaning rags.
14. Scraps of various types of material.
15. Assortment of needles and threads.
16. Necchi T-Wrench (for Nut No. 21339) and Wrench No. 40-6 (for Nuts Nos. 45 and 59).
17. Special screw driver and perforated ring for adjusting the Zig-Zag mechanism. (Figs. 63 - 64 - 65).

After a short examination of the machine, a good mechanic will be able to state with certainty whether the machine sews correctly or not and, consequently, whether repairs are required. Many times a customer calls in a mechanic to have a machine repaired which supposedly is out of order. Quite often the customer attributes the poor performance of the machine to imaginary defects of some of the sewing machine parts, while in reality the trouble lies in the customer's own lack of experience in using the machine.

There are four fundamental questions every mechanic should ask in investigating the customer's knowledge with regard to the machine:

1. Does the customer know what type and size of needle to use and how to insert the needle in the machine?
2. Does the customer know how to thread the machine correctly?
3. Does the customer know how to clean the shuttle race?
4. Does the customer know how to judge the tensions of upper and lower thread and how to adjust these tensions, if necessary?

### *Instructions to be given to the customer*

#### *1. Using the correct needle.*

The needle must be selected in accordance with the type of material to be sewn, the kind of work to be performed and the thickness of the thread to be used (see « Needle and Thread Chart » in Instruction Booklet).

To insert the needle, proceed as follows:

Turn the balance wheel by hand toward you until the needle bar reaches its highest position, then insert the needle so that the flat portion of its shank faces the groove in the needle bar. Push the needle up into the needle bar as far as it will go, then tighten firmly the screw in the needle clamp so that the needle is held securely in the needle bar (see Figs. 5 and 6).

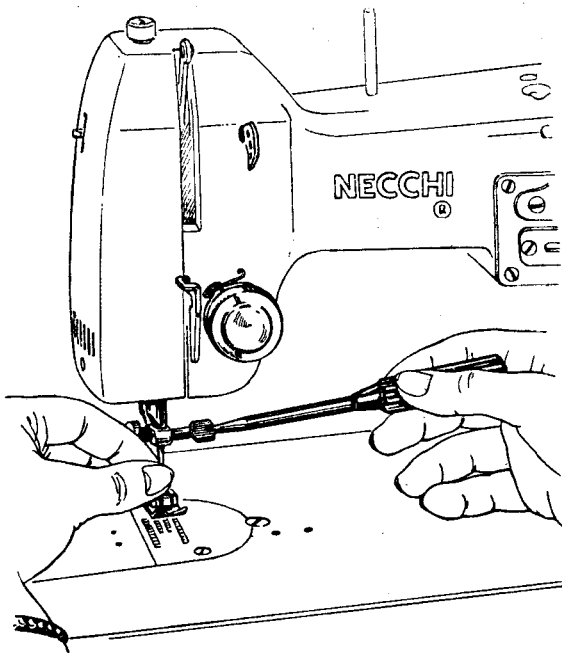

Fig. 5

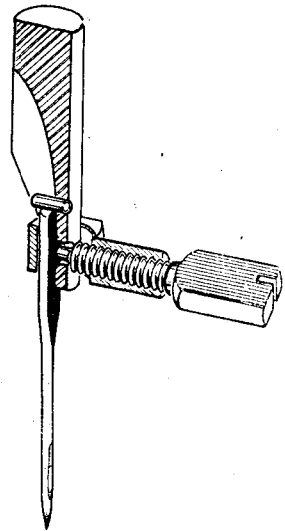

Fig. 6

## 2. Correct Threading of the BF and BU Mira Machines.

Proceed as follows:

- a. Bring the needle to its highest position by turning the balance wheel slowly towards you.
- b. Place the spool of the thread on the spool pin « H » and run the thread through the thread guide « S » (see Fig. 7).
- c. Draw the thread down, then insert it from right to left in the slot of the tension disc housing « U ». Next, bring the thread up and then down over the thread take - up spring (Check Spring) « D » (see Figs. 7 and 7 a).
- d. Draw the thread down, under the thread guide tension arm « A »; guide it, across the notch « F », through thread guide « G ».
- e. Guide the thread upward, and from right to left, through the eye of the thread take-up lever « L ».
- f. Draw the thread down, guiding it again through the thread guide « G ».

g. Run the thread in the notch «K» between the arm of the machine and the face plate «R», then pull it towards the left until it slides behind the pin «M» (which can be seen through the notch «K») and comes out under the face plate «R».

h. Guide the thread from back to front through the needle clamp thread guide «N» (and for the BU MIRA, guiding it back again from front to back).

i. Insert the thread, from left to right, through the eye of the needle «T», leaving about four inches of free thread hanging from the needle.

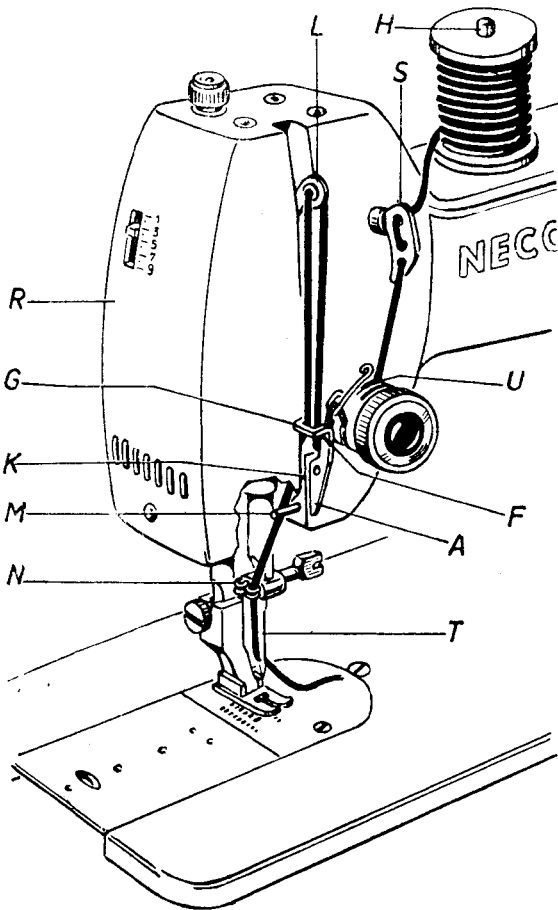

Fig. 7

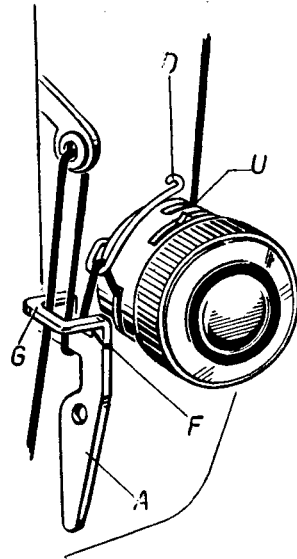

Fig. 7 a

### **3. Correct Threading of the BF and BU NOVA Machines.**

- a. Bring the needle to its highest position by turning the balance wheel slowly towards you.
- b. Place the spool of the thread on the spool pin « H » and run the thread over the thread guide « S » (see Fig. 8).
- c. Draw the thread down, then insert it from right to left in the slot of the tension disc housing « U ». Next, bring the thread up and then down over the thread take-up spring (Check Spring) « D » (see Figs. 8 and 8 b).
- d. Draw the thread down, under the thread guide tension arm « A »; guide it, across notch « F », through thread guide « G ».
- e. Guide the thread upward, and from right to left, through the eye of the thread take-up lever « L ».
- f. Draw the thread down and guide it through the thread guide « C » of the face plate « R » by pulling it from back to front.
- g. Guide the thread through the needle clamp thread guide « N » by drawing it from back to front (for the BU NOVA, draw it again from front to back).
- h. Insert the thread, from left to right, through the eye of the needle, leaving about four inches of free thread hanging from the needle.

### **4. Cleaning the Shuttle Race.**

- a. Bring the needle to its highest position by turning the balance wheel slowly toward you.
- b. Tilt the machine back on its hinges so that the underside is in full view.
- c. Remove the bobbin case by lifting the latch lever with thumb and forefinger of the left hand and pulling the bobbin case out of the machine (see Fig. 9).

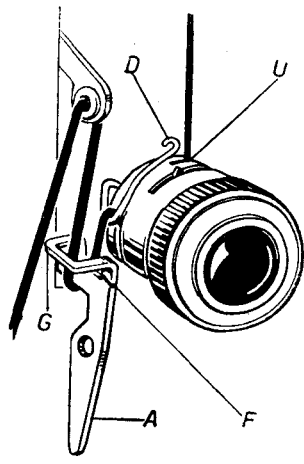
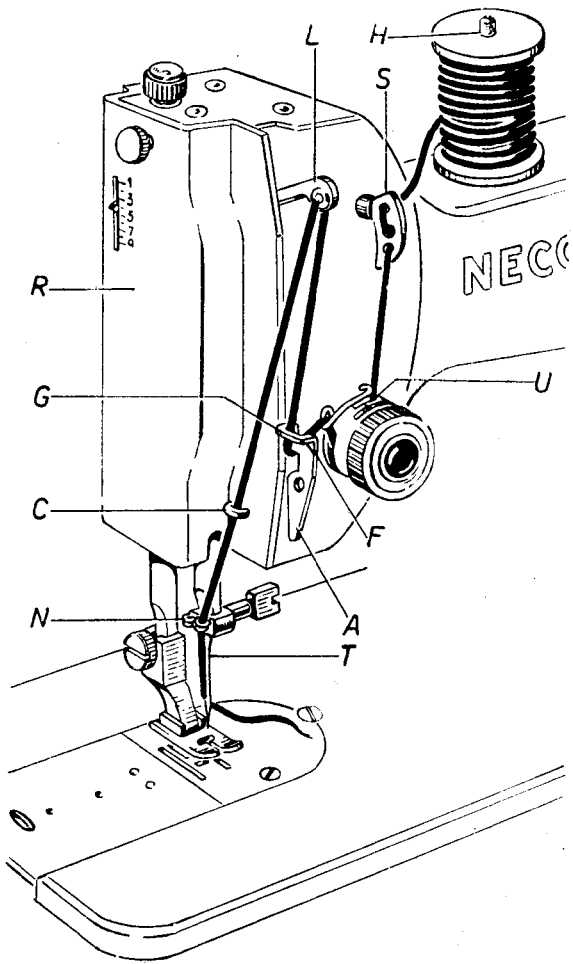
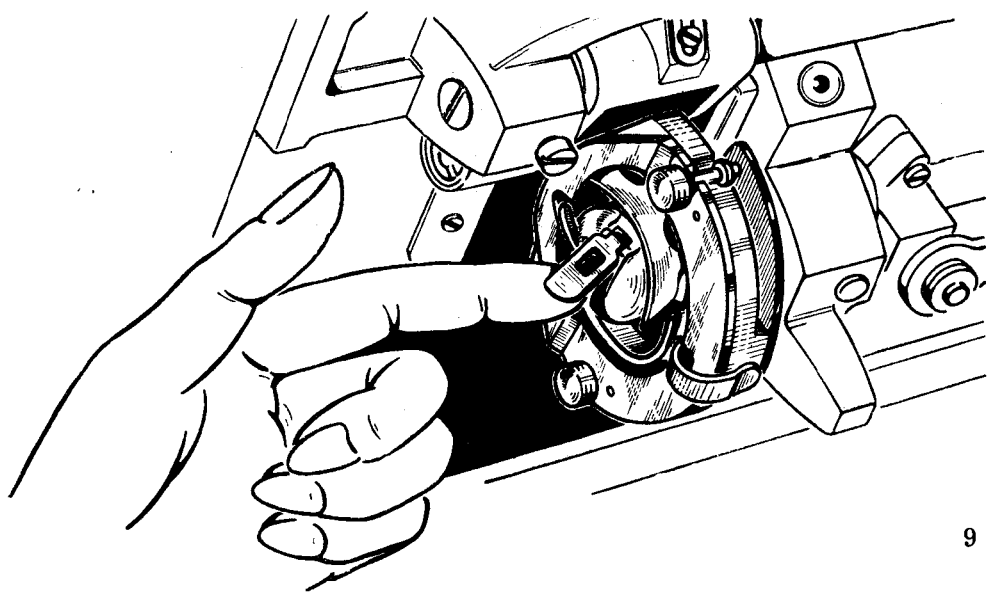

Fig. 8 b

Fig. 8

Fig. 9



- d. Push the two race snap pins « Z » (see Fig. 10) outward, then remove the race cover plate « T » by pulling it away from the shuttle race.
- e. Remove the shuttle « R » by pulling it out of the shuttle race. This leaves the raceway free for cleaning.
- f. Remove lint and pieces of thread with a soft rag then clean the shuttle race with the small brush (see Fig. 11), dipped in kerosene, and wipe the shuttle race dry. Next, put a drop of oil into the raceway and on the rim of the shuttle.
- g. To replace the shuttle, insert it into the shuttle race with the thumb and forefinger of the left hand (see Fig. 12), fitting it without force into the place opposite the shuttle carrier.
- h. Place the race cover plate « T » into the two small studs « G » and push the race snap-pins « Z » back into their former position. (see Fig. 10).
- i. Reinsert the bobbin case, then bring the machine back into its working position.

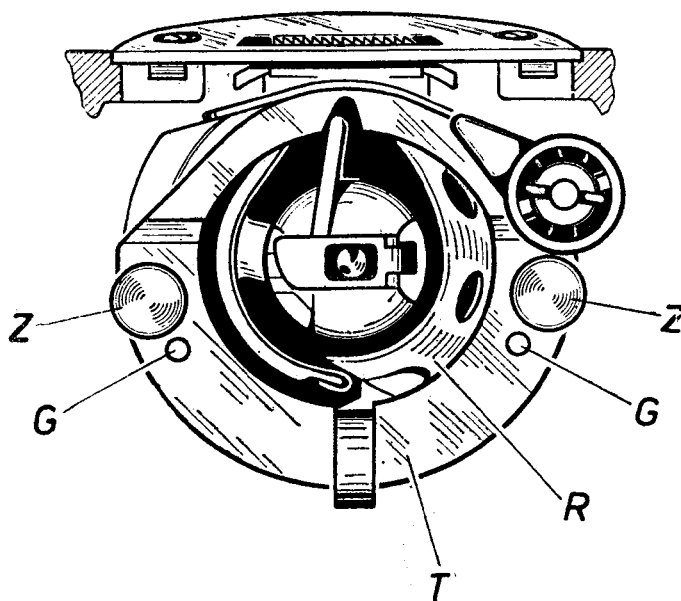

Fig. 10



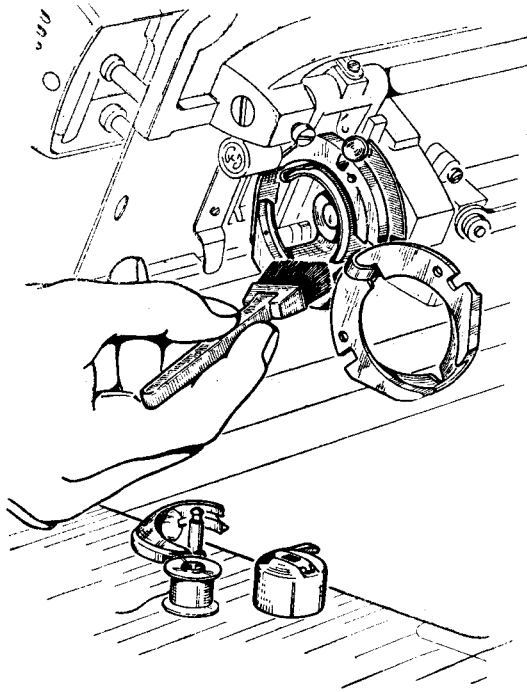

Fig. 11

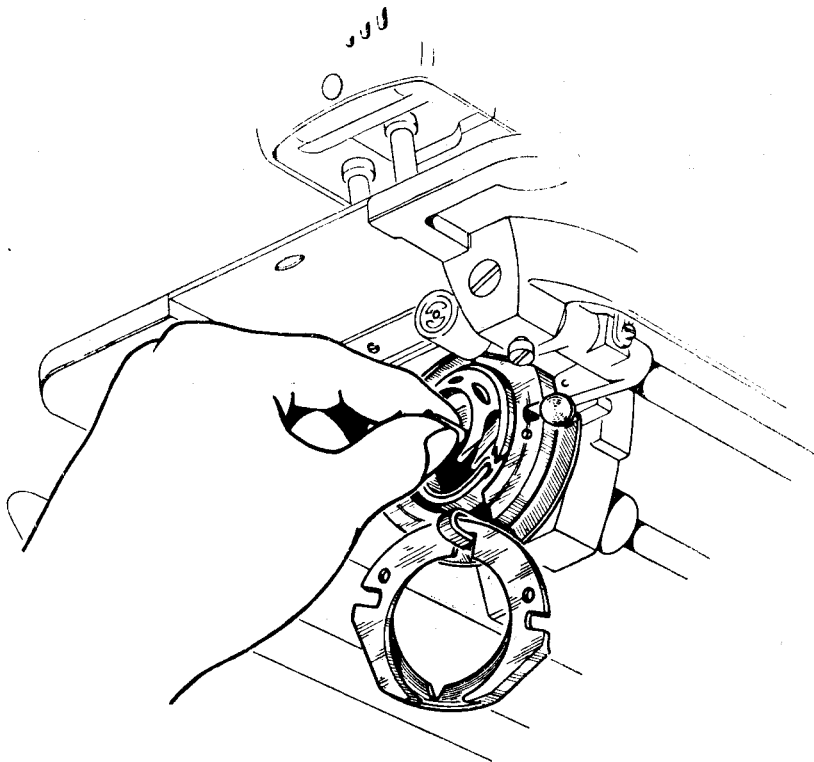

Fig. 12

### 5. *Adjusting the Thread Tensions.*

The tensions of upper and lower thread are correctly balanced if both threads interlock in the center of the fabric, as shown in Figure 13.



Fig. 13

If the tension of the upper thread is too strong in relation to that of the lower thread, the lower thread will be pulled up to the top surface of the fabric and appear there in the form of small knots (see Fig. 14).



Fig. 14

If the tension of the lower thread is too strong in relation to that of the upper thread, the upper thread will be pulled down to the bottom surface of the fabric and appear there in the form of small knots or loops (see Fig. 15).



Fig. 15

## ELEMENTARY INSTRUCTIONS ON MACHINE MAINTENANCE

To keep the machine in good working condition, it is essential to clean it frequently and to lubricate it regularly.

### 1. *Cleaning.*

To clean the machine, prepare a mixture of 90 % kerosene and 10 % lubrication oil. Fill an oil can with the cleaning fluid, and also pour a sufficient quantity of this liquid into a pan.

If the machine, due to dirt and gummed oil, runs heavily, force with the oil can plenty of the cleaning fluid into all oil holes and on all movable parts. Then run the machine at high speed until all dirt and hardened oil are washed out.

Should some parts of the various mechanisms of the machine have become badly clogged with dirt and gummed oil, remove these parts from the machine and place them for a while into the pan filled with cleaning fluid. After the dirt and gummed oil have become loose, clean the parts with a small brush dipped in the cleaning fluid. Then wipe them dry with a soft clean rag.

The electric motor must always be kept dry. Only the motor shaft requires a few drops of oil from time to time.

### 2. *Lubrication.*

After the machine has been wiped clean with a rag, apply a drop of good oil to every movable part; to the bearings of the lower shaft (to which the shuttle carrier is attached) and to all other shaft bearings of the machine. The various oil holes in the machine indicate where the oil must be applied. Make certain to use only NECCHI lubricating oil.

### **3. General Remarks.**

Although the approximately 430 parts, which comprise a NECCHI BU machine, vary in size and shape, the maintenance and repair of each part is quite simple. The flawless operation of the machine requires adjustments which are limited to only 12 basic subjects:

1. Timing (coordinating) the movements of the various groups of movable parts in relation to each other.
2. Assembly and adjustment of the arm shaft.
3. Assembly of the needle bar with the needle clamp.
4. Positioning of the needle bar.
5. Adjustment of the presser bar.
6. Adjustment of the thread tensions.
7. Assembly of shuttle carrier with shuttle carrier shaft and adjustment of the oscillating shuttle in relation to the needle bar.
8. Assembly and adjustment of the stitch control mechanism.
9. Adjustment and operation of the bobbin winder mechanism.
10. Adjustment of the zig-zag mechanism.
11. Proper care of the motor.
12. Setting up the machine head in the appropriate cabinet.

## **TECHNICAL CHARACTERISTICS OF NECCHI SEWING MACHINES**

The BF machine, designed for household use, is equipped with an oscillating shuttle, a central bobbin case and a calibrated thread tension. It makes a straight seam, performs a lockstitch, and can be adjusted for forward and backward sewing.

The BU machine, also intended for household use, is equipped with an oscillating shuttle, a central bobbin case, and a calibrated thread tension. It makes a lockstitch and can be adjusted for straight and zig-zag sewing.

*Note:* Each machine head is identified by a serial number which can be found at the lower front portion of the bed plate. In the BU Nova machines, the letter «U» precedes the serial number; in the BF and BU Mira machines, the letter «M».

## ADJUSTING THE MOVEMENTS OF THE VARIOUS GROUPS OF PARTS IN RELATION TO EACH OTHER (TIMING THE MACHINE)

To obtain a continuous and satisfactory performance from the machine, the movements of the various groups of parts in relation to each other must be adjusted (timed) in such a manner that the actions of these parts repeat themselves regularly at certain fixed time intervals.

In the following are explained the most important timing procedures, omitting operations which are solely performed on the assembly line in the factory where the machines are made.

For each *timing procedure* is also mentioned the corresponding *timing gauge* which should be part of the mechanic's equipment. Furthermore, whenever possible, a *general rule* for the timing procedure in question is given, in case the corresponding timing gauge should not be available to the mechanic.

Timing performed in accordance with the rules set down in the following chapters is indispensable when:

1. One or several elements of a group of parts have been replaced whose actions depend on those of another group of parts, or when entire groups of parts, depending on each other, must be removed and replaced.
2. It is necessary to check the proper function of a group of parts in relation to another group of parts, the movements of these groups depending on each other.
3. Certain disturbances must be eliminated which interfere with the proper progress of sewing.

The following three interdependent adjustments are essential:

1. The timing of the movements of shuttle and needle bar.
2. The timing of the movements of feed dog and needle bar.
3. The timing of the movements of the zig-zag mechanism and the needle bar.

*Note:* Our machines have subassemblies which are installed and held in the machines by permanent fixing means (e. g. tapered pins, etc.) and cannot be adjusted once they are assembled within the machine. We, therefore, guarantee perfect timing of such assemblies.

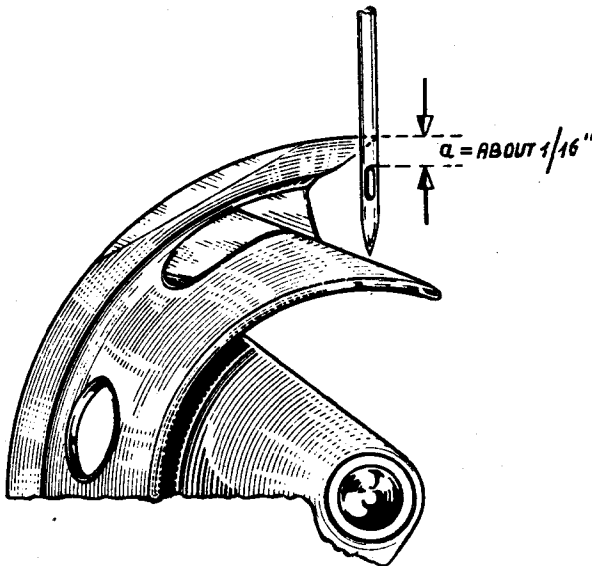

Fig. 16

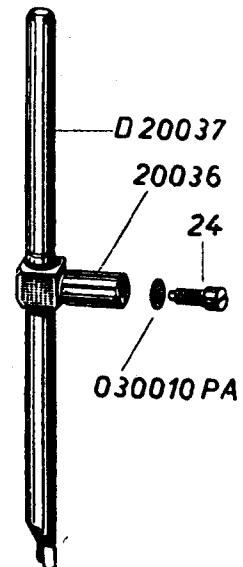

Fig. 17

## TIMING OF SHUTTLE AND NEEDLE BAR IN THE BF NOVA AND BF MIRA MACHINES

### I *Adjustment - Height of the Needle Bar.*

Turn the balance wheel by hand toward you until the point of the shuttle is just at the center of the rising needle.

At this moment the point of the shuttle should be about  $1/16''$  above the upper part of the needle eye (Fig. 16). If the distance  $a$  is more or less than  $1/16''$ , an adjustment is necessary. Loosen slightly the screw No. 24 (Fig. 17) in the needle bar connecting stud No. 20036 so that the needle bar No. D 20037 is still held in position by friction.

Now, without turning the balance wheel, push the needle bar up or down by hand until the distance  $a$  is equal to about  $1/16''$ . Tighten screw No. 24 firmly after this adjustment.

This adjustment can also be achieved with the aid of the TIMING GAUGE No. AC 4/75. The gauge is composed of a body similar to the shuttle and of a false needle (gauge pin), contained in the upright of the gauge so that it won't be misplaced. In the following a description of the use of this gauge is given:

#### **1. Insertion of the TIMING GAUGE No. AC 4/75.**

- a. Turn the balance wheel by hand and bring the needle bar to its highest position (Fig. 18).
- b. Replace the normal needle of the needle bar with the false one of the gauge. The false needle is inserted the same way as normal one.
- c. Remove the race cover plate No. 26333 and the shuttle No. 26327.
- d. Insert the shuttle-shaped gauge AC 4/75 into the shuttle race (Fig. 18).

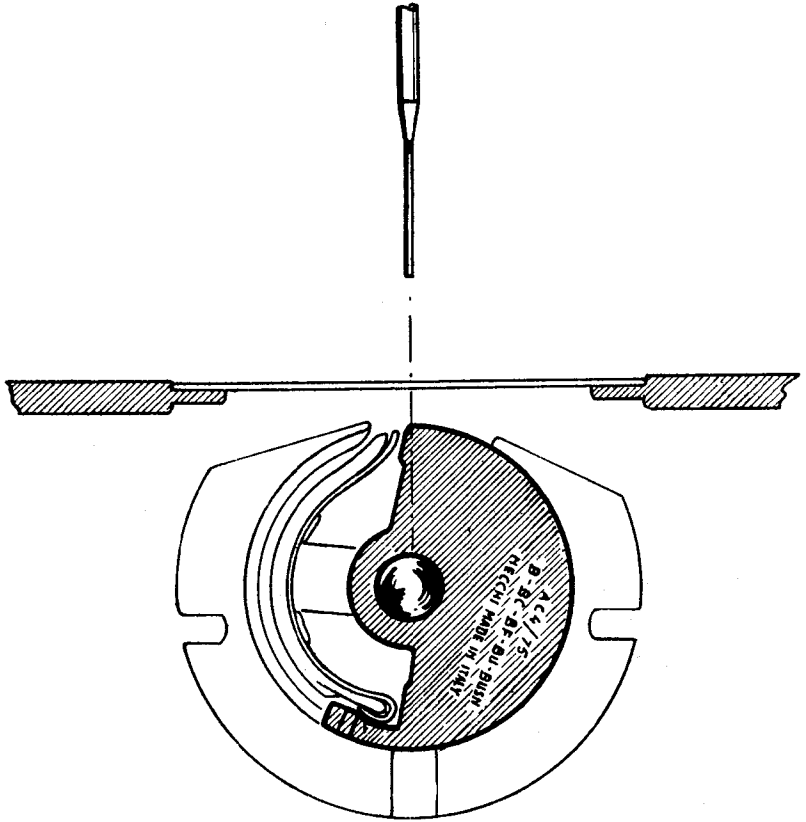

Fig. 18

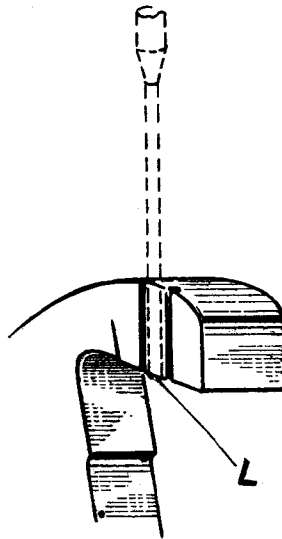

Fig. 19



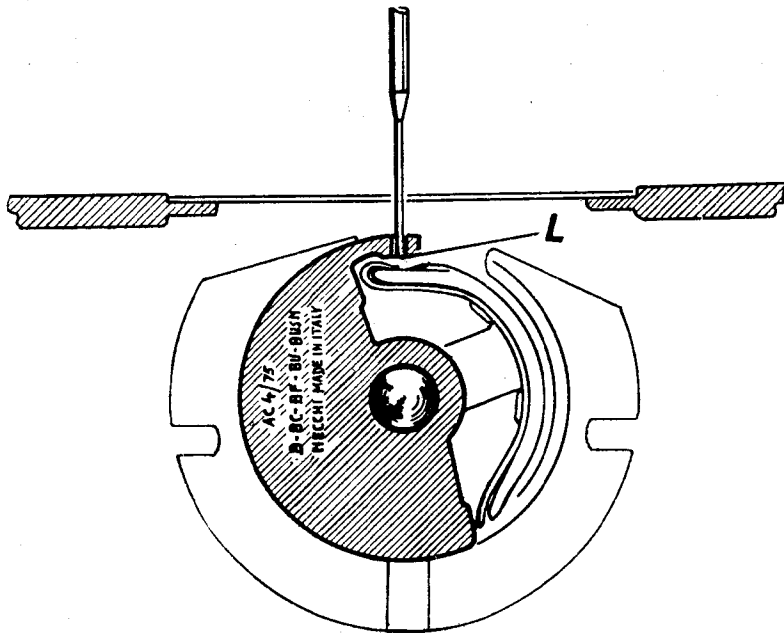

Fig. 20

## 2. Timing Procedure.

a. Bring the needle bar to its lowest position. In this position, the lower end of the false needle should be just in line with the lower edge «L» of the prong of this gauge, as shown in Figs. 19 and 20. If an adjustment of the height of the needle bar is necessary, loosen slightly screw No. 24 (Fig. 17) so that the needle bar is still held in position by friction. Then, without turning the balance wheel, move the needle bar up or down by hand until the condition shown in Figs. 19 and 20 is met. Tighten screw No. 24 firmly.

## II Adjustment - Distance Between the Needle and the Shuttle.

Without touching the needle, the point of the shuttle should be brought as close as possible to the needle (Fig. 21). If the point of the shuttle is too far from the needle, loosen the screw «F».

(Fig. 22) under the bed plate. Then move the race body No. D 26330 with the shuttle carrier in an axial direction, as required, until the shuttle comes sufficiently close to the needle without touching it. Before tightening the screw « F » adjustment III should be checked.

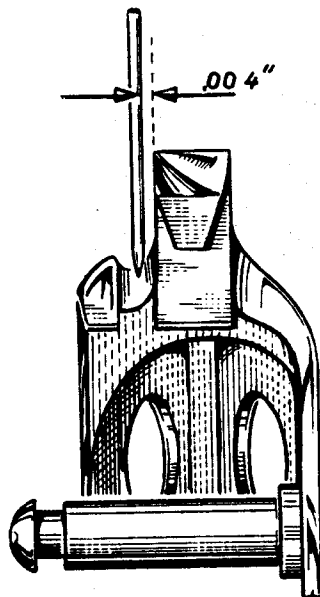

Fig. 21

### **III Adjustment - Centering the Needle in Relation to the Race Cover Plate.**

The needle « A » should pass through the center of the slot in the race cover plate No. 21330 (Fig. 23). If the needle passes too close to the edges BB of this slot in the race cover plate No. 21330, there is the danger that it may break.

To perform this adjustment, rotate the race body No. D 26330 around its axis, without moving it in an axial direction. Now, the screw « F » can be firmly tightened (Fig. 22). (After the III adjustment, it is advisable to check adjustment II again).

### **IV Adjustment - Position of the Needle Eye in Relation to the Shuttle.**

Follow same procedure as for BU machines (see II Adjustment at Page 22).

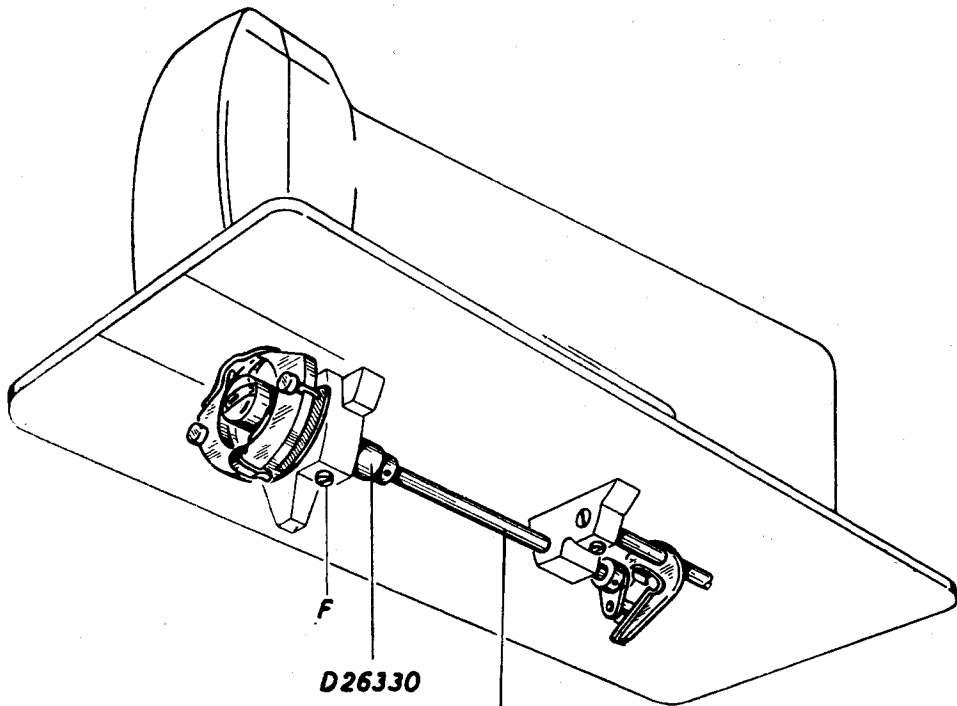

**C26325**

**Fig. 22**

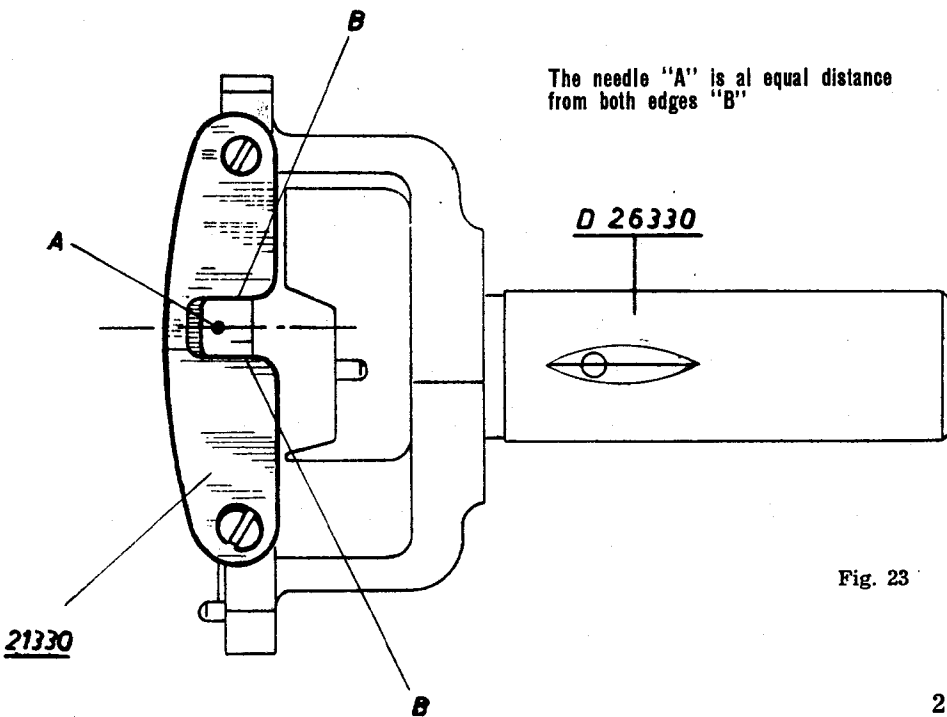

**Fig. 23**

## TIMING OF SHUTTLE AND NEEDLE BAR IN THE BU NOVA AND BU MIRA MACHINES

### I. Adjustment - Height of Needle Bar.

(See Adjustment I for BF machines).

In machines with a double needle, this adjustment is always made using only one needle.

### II. Adjustment - Position of the Needle Eye in Relation to the Shuttle.

The needle bar must be lined up in such a way that the center line of the needle eye is perpendicular to the shuttle (Fig. 24), i.e. the needle eye must *not* lie *obliquely* in relation to the point of the shuttle (Fig. 24 A). This cause the loop of the thread to be arranged in such a way that it can be easily caught by the point of the shuttle. This is specially necessary when the machine sews with two needles.

In order obtain the above mentioned condition, it is necessary that the needle bar clamp No. D 26295 (Fig. 25) be firmly tightened and that axis *a* of the needle clamp No. D 26295 be directed parallel to axis *b* of the upper shaft No. C 26010 (Fig. 25) or, what amounts to the same thing, that the axis *a* of the needle bar clamp No. D 26295 be in direction of the longitudinal axis of the machine.

If it is necessary to make an adjustment, proceed as follows:

- a. Loosen slightly the screw No. 24 of the needle bar connecting stud No. 26025 (Fig. 29).
- b. Without moving it up and down, rotate the needle bar about its own axis in the required direction until it is in the position shown in Fig. 25.
- c. Tighten screw No. 24 firmly.

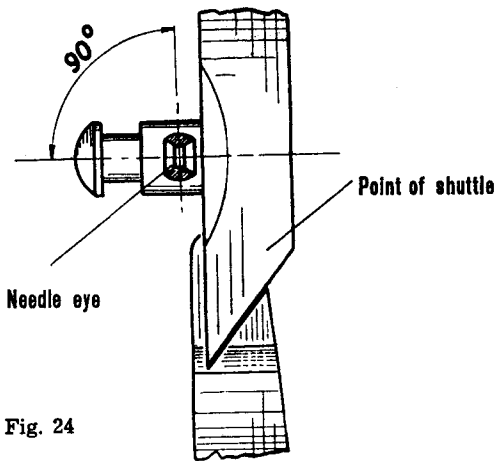

Fig. 24

Needle eye in correct position

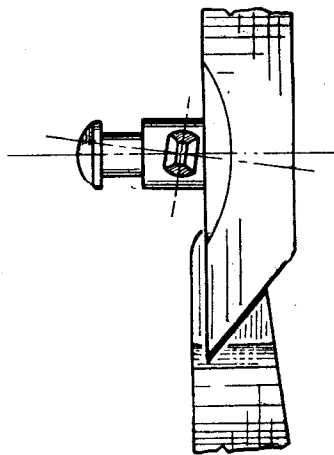

Fig. 24 A

Needle eye in incorrect position

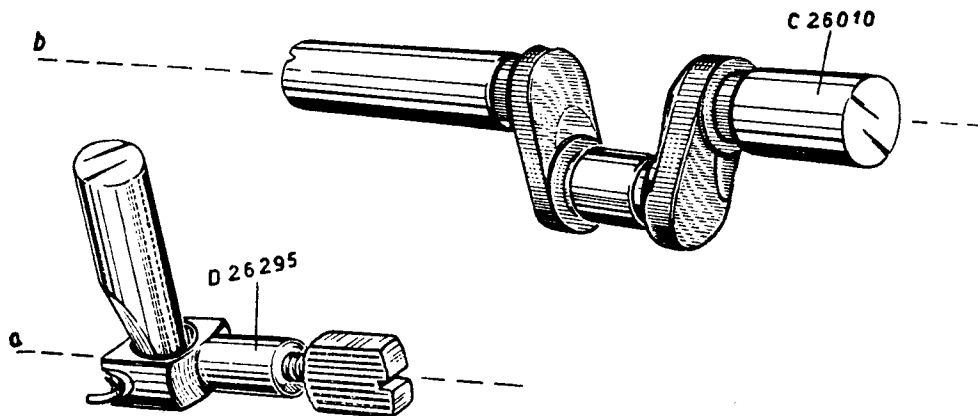

Fig. 25

### III Adjustment - Distance between the Needle and the Shuttle.

Without touching the needle, the point of the shuttle should be as close as possible to the needle (see Fig. 21 for the BF). If the point of the shuttle is too far away from the needle, loosen the screw « F » (Fig. 26) below the bed of the machine. Then, move the race body No. D 26330 with the carrier shaft in axial direction until the shuttle comes as close to the needle as possible without touching it. Before tightening the screw « F », adjustment IV should be checked.

### IV Adjustment - Centering the Needle in Relation to the Race Cover Plate.

The single needle A should pass exactly through the center of the slot (Fig. 27) in the race cover plate No. 21330. In the twin-needle machine the correct position of the needles is that shown in Fig. 28. To perform this adjustment, rotate the race body, No. D 26330, without moving it in an axial direction, around the carrier shaft No. C 26325. Now, the screw « F » can be firmly tightened (Fig. 26). All four adjustments mentioned can also be achieved with the aid of the TIMING GAUGE No. AC 4/68:

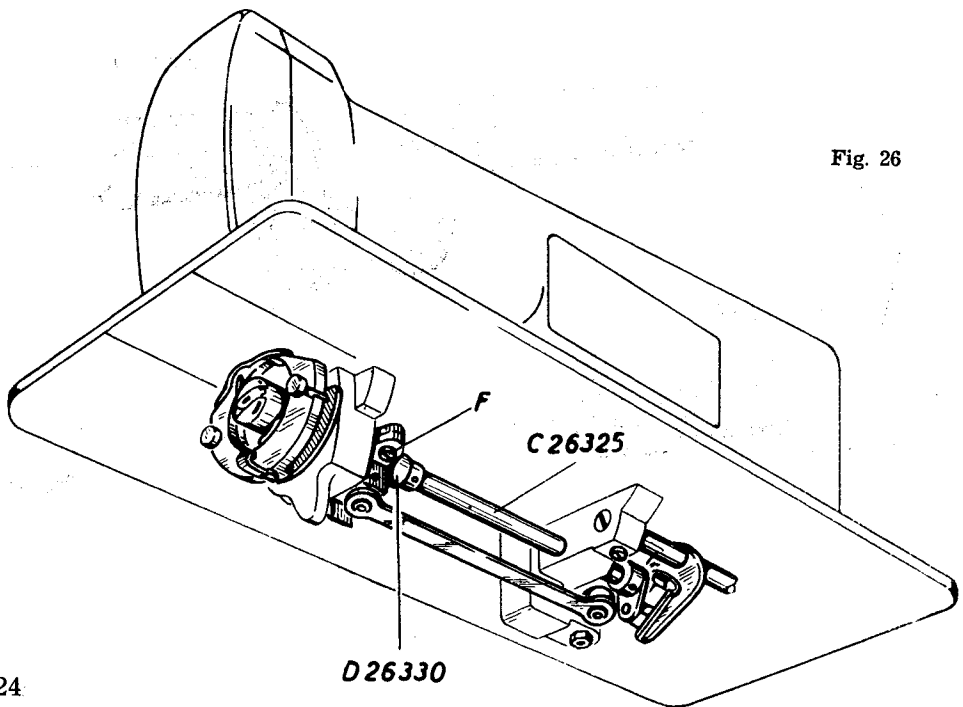

Fig. 26

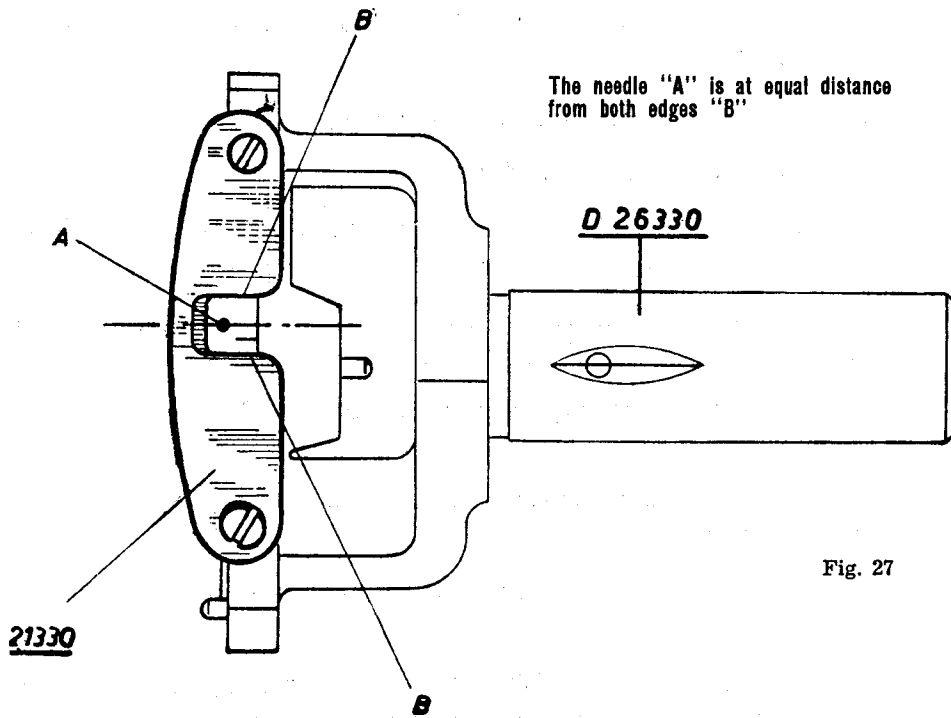

Fig. 27

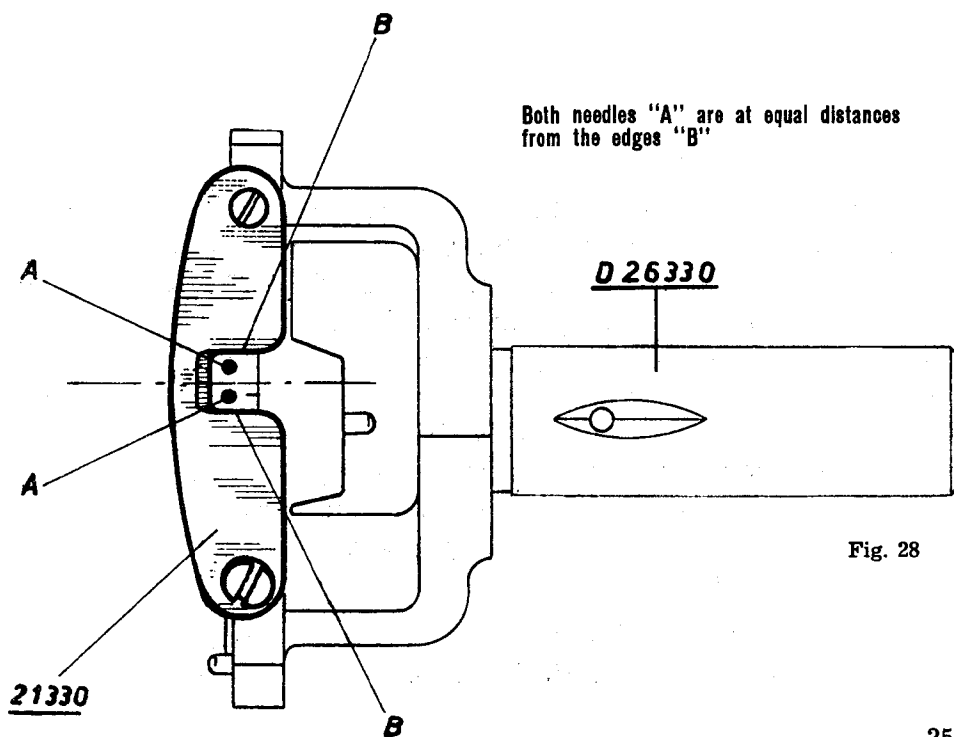

Fig. 28

**1 - Insertion of the Timing Gauge No. AC 4/68 and of the Square-angled Bar E. (Fig. 29).**

- a. Remove the presser foot and the needle plate.
- b. Remove the needle and the shuttle.
- c. Insert bar « E » (Fig. 29) of the gauge into the needle bar, following the same instructions as for the insertion of a needle.
- d. Loosen screw No. 24 of the needle bar connecting stud No. 26025 so that the needle bar is still held in position by friction.
- e. Hold the machine firmly and push the needle bar upwards about  $7/32$ ".
- f. By turning the balance wheel by hand, bring the needle bar « C » to its lowest position.

From this point onward and during the timing operation, DO NOT turn the machine.

- g. Insert the gauge No. AC 4/68 into the race body and fix it by means of two knobs « H » and the two reference pins « G ».

**2 - Timing Procedure.**

If, by pushing down the needle bar by hand while the balance wheel is held firmly, the lower end of the bar « E » enters exactly into the rectangular hole in the prong of the gauge No. AC 4/68 (Fig. 29), then the requirements of paragraphs II, III, and IV have been satisfied. In order to comply also with the requirements of paragraph I, push the step « I » of the bar « E » until it stops against the outside of the gauge No. AC 4/68 (Fig. 29).

Now, tighten screw No. 24 and remove the gauge. If, by pushing down the needle bar by hand, the lower end of the bar « E » does not enter the rectangular hole in the prong of the gauge No. AC 4/68, then adjust as follows:

- h. Loosen the screw « F » below the bed of the machine (Fig. 26) in order to allow the race body No. D 26330 to move freely.



- i. Move the race body No. D 26330 and the needle bar « C » simultaneously until the lower end of the bar « E » enters the rectangular hole in the prong of the gauge.
- l. Push the step « I » of the bar « E » by hand (Fig. 29) until it stops against the outside of the gauge.
- m. Firmly tighten the screw No. 24 of the needle bar connecting stud. No. 26025.
- n. Firmly tighten the screw « F » (Fig. 26) below the bed of the machine.
- o. Remove the gauge.

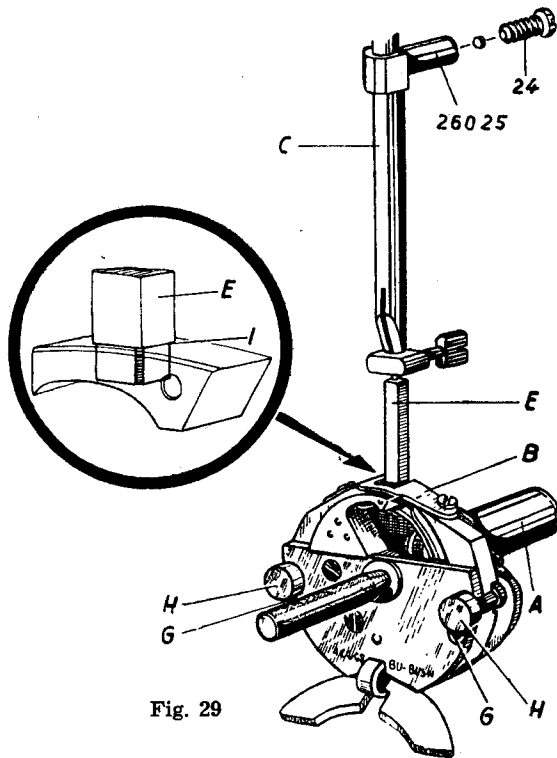

Fig. 29

**3 - To Remove the Gauge AC 4/68.**

- a. Rotate the balance wheel slightly, just enough to bring the lower end of the bar « E » out of the hole in the gauge.
- b. Remove the gauge No. AC 4/68.
- c. Remove the bar « E ».
- d. Reassemble the machine.

## IMPORTANT - ADJUSTMENT OF THE SHUTTLE CARRIER SHAFT IN BF AND BU MACHINES

In the BF and BU Nova and Mira NECCHI machines, the oscillating shaft crank No. D 26306 is pinned to the carrier shaft No. 26325 (Fig. 30). In these machines, therefore, the angular position of the shuttle carrier at one end of the carrier shaft in relation to the oscillating shaft crank at the other end of this shaft remains always the same.

If in these machines it should be necessary to replace the old carrier shaft No. 26325 with a new one, the shuttle carrier No. D 26340 and the oscillating shaft crank No. D 26306 must be placed in the proper angular position in relation to each other. Proceed as follows:

1. Place and pin the shuttle carrier No. D 26340 (Fig. 30) to one end (the one closest to the circumferential lines) of the carrier shaft No. 26325, then assemble with machine. Place the oscillating shaft

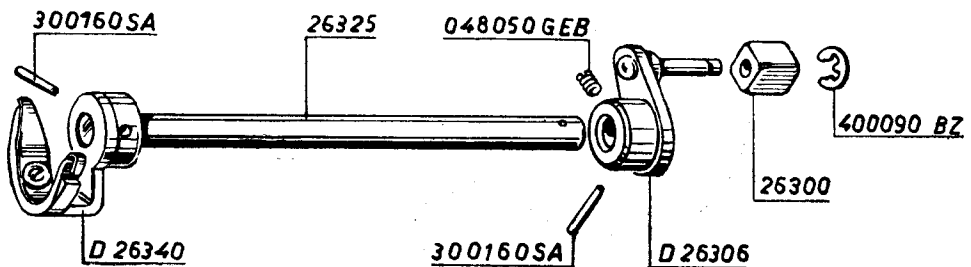

Fig. 30

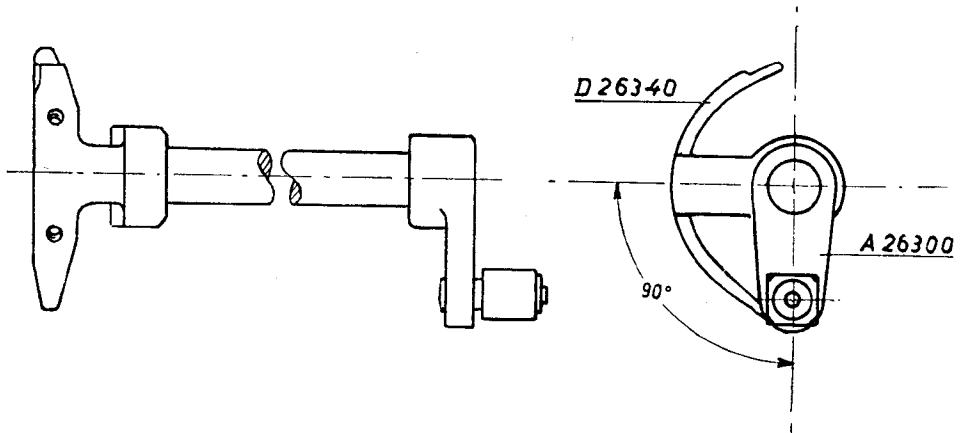
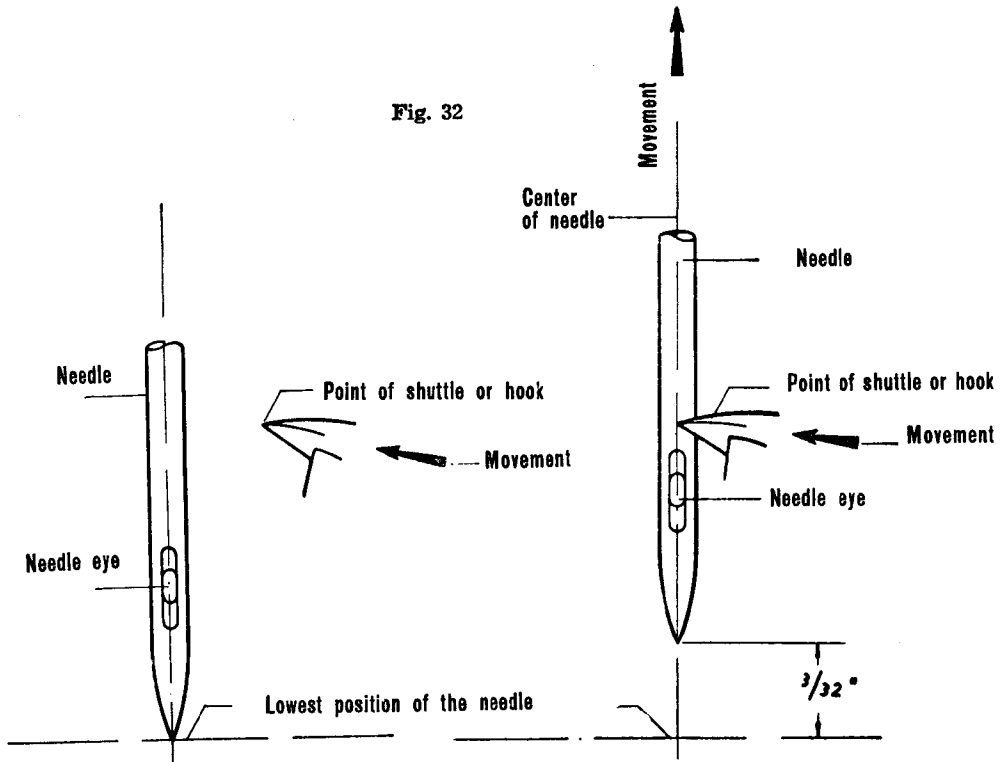

Fig. 31

crank No. D 26306 on the other end of carrier shaft in such a position that shuttle carrier and oscillating shaft crank include an angle of about 90 degrees (as indicated in Fig. 31). This angular position is approximately correct but it must be checked (see item 2). Now, tighten firmly the set screw No. 048050 GEB in the oscillating crank shaft (Fig. 30). Assemble the machine completely.



2. Check the timing of the shuttle and the needle in the following manner:

Turn the balance wheel slowly by hand until the needle is raised about  $\frac{3}{32}$ " above its lowest position. At this moment, the point of the shuttle should be exactly in the center of the rising needle (Fig. 32). If this requirement is not met, loosen the set screw No. 048050 GEB in the oscillating crank shaft (Fig. 30) and turn the carrier shaft No. 26325 in the required direction until the point of the shuttle has reached the center of the needle which has remained stationary. Tighten firmly the set screw No. 048050 GEB.

Operation No. 2 can also be performed with the aid of the TIMING GAUGE No. AC 4/75 in the following manner:

Insert the gauge No. AC 4/75 as explained in the paragraph: «Timing of shuttle and needle bar in the BF Nova and Mira». Bring the needle bar to its lowest position. In this position, the false needle, if correctly adjusted, will lie between the two timing lines «A» (Fig. 33). If the needle does not lie between the two timing lines «A», loosen the screw No. 048050 GEB (Fig. 30). Now, without moving the balance wheel, turn the carrier shaft by hand in the required direction until the false needle comes to lie between the two lines «A». Tighten the screw No. 048050 GEB firmly and remove the gauge.

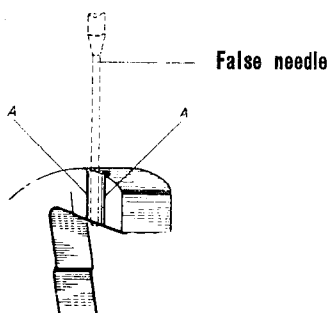

Fig. 33

3. Carry out the adjustment I, II, III on pag. 10 and 11 for the BF machines and the adjustment I, II, III, IV on pag. 11 and 12 for the BU machines. Now, sew with the machine.

4. a. If the machine sews correctly:

Place a pointed pin into the tapered pin hole of the oscillating shaft crank and mark on the carrier shaft the position of the hole to be drilled and reamed in the carrier shaft. Remove the carrier shaft assembly, then drill and ream the tapered pin hole in the carrier shaft. Next assemble with machine, using the tapered pins No. 300160 SA. For reaming tapered holes use tapered reamer No. 3/0. After this operation, it is advisable to perform the adjustment II and III on page 20-21 for the BF machines and the adjustments II, III, IV on page 22-24 for the BU machines.

b. If the machine does not sew properly repeat operation No. 2 until the machine performs perfect sewing. Then drill, ream and pin as explained in paragraph 4 a.

## TIMING OF FEED DOG AND NEEDLE BAR

### GENERAL RULE

The feed dog must be adjusted in such a manner that it starts to move away from the operator at about the time the needle begins its downward movement from its highest position. The feed dog must have finished its forward (feeding) motion at the time the point of the descending needle is about to enter the fabric. The feed dog must not move the fabric while the needle is still in the fabric.

If the feed dog is not correctly timed in relation to the needle, adjust as follows:

Remove the plate No. 20301 from the back of the arm. Turn the balance wheel by hand in the direction of sewing, to bring the screws No. 048080 GEN of the feed eccentric No. 20026 (see Fig. 34)

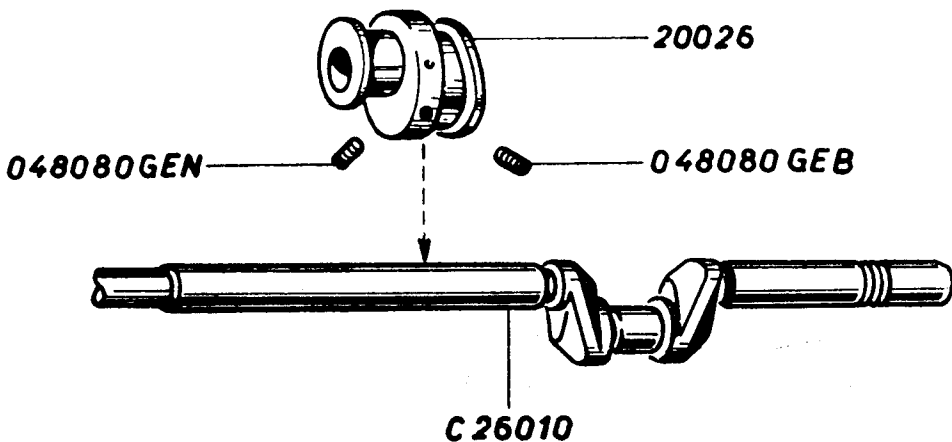

Fig. 34

into sight and loosen them slightly. Turn the feed eccentric on the upper shaft No. C 26010, making certain not to move it in an axial direction, until the feed dog moves correctly as explained above. Tighten the aforementioned screws firmly after this adjustment. As a guiding fact it should be mentioned that the feed dog is approximately correctly timed when in the horizontal position of the cranked portion « P » of the upper shaft (see Fig. 35) the first one of the two set screws No. 048080 GEN lines up with the axis of the upper shaft.

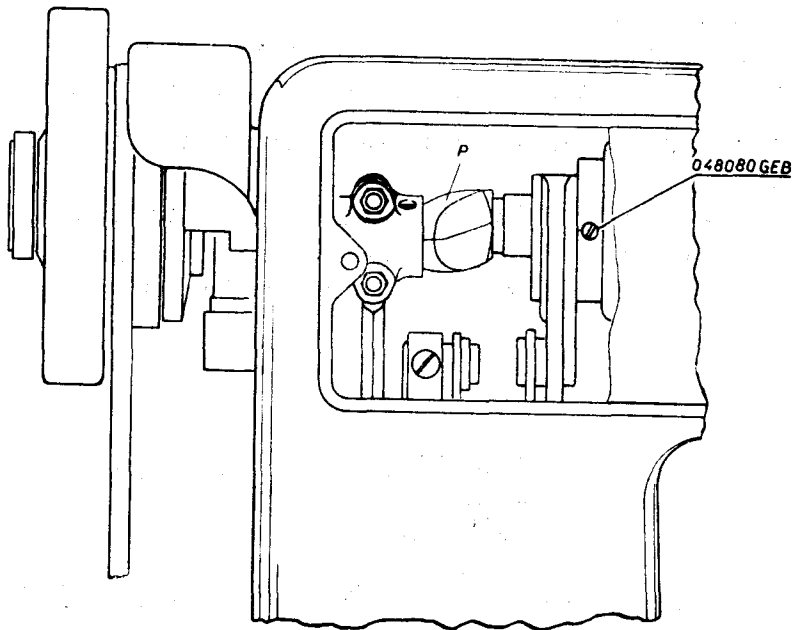

Fig. 35

The timing of feed dog and needle bar in relation to each other can also be achieved with the aid of the timing gauge No. AC 4/2. In the following, a description of the use of this gauge is given:

1. Introduce the pin « B » which is fastened to the upper part of this gauge (see Fig. 36) into the corresponding timing hole of the feed eccentric « A ».
2. Turn the balance wheel slowly in the direction indicated in Figure 36 until the fibre base « D » of the timing gauge « C » rests firmly on the bed plate of the machine, as indicated in Figure 36.

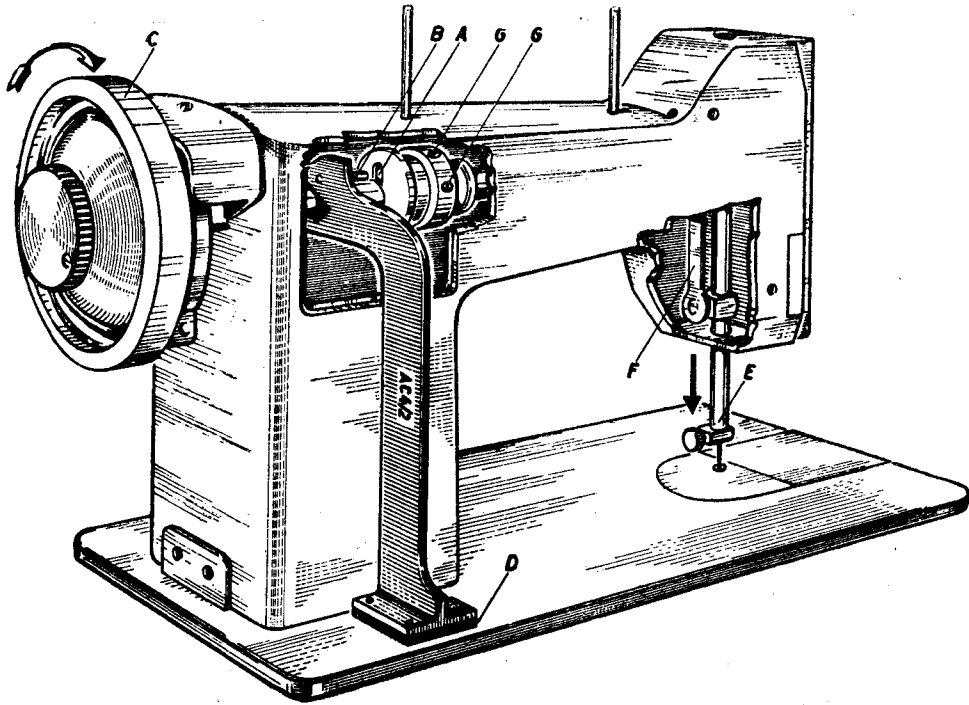

Fig. 36

3. If timed correctly, the needle bar « E » must at this moment be in its lowest position, and the needle bar connecting link « F » must have a vertical position in the machine.

4. If the requirements outlined in the preceding paragraph are not met, loosen the two screws « G » in the feed eccentric « A », and while leaving the timing gauge supported by the bed plate and keeping it inserted in the timing hole of the feed eccentric « A », turn the balance wheel « C » slowly in the direction indicated in Figure 36 until the needle bar « E » reaches its lowest position. Firmly tighten the two screws « G » after this adjustment. The timing procedure outlined in the preceding paragraphs will induce the feed dog move in correct relation to the needle bar.

## TIMING THE ZIG-ZAG MECHANISM AND THE NEEDLE BAR (FOR BU MACHINES ONLY)

### GENERAL RULE

Adjust the machine for *straight and central* stitching (zig-zag control lever is at « O » and needle displacement lever at the center).

Remove the plate No. 26186 at the front of the machine arm, making certain not to move the zig-zag control lever. Turn the balance wheel by hand until the needle bar is in its highest position. At this position of the needle bar, the eccentric « E » of the assembly No. C 26201 (see Fig. 37) should occupy either Position I, or Position II in the component upper channel of the oscillating lever No. 26131, as indicated in Figures 38 and 39.

Should, at the highest position of the needle bar, the eccentric « E » possess a different position than those shown in Figures 38 and 39, loosen both screws No. 048040 GEB in the upper shaft gear No. 26240 (see Fig. 40), then turn this gear around the upper shaft No. C 26010 until the eccentric « E » gets into one of the positions I or II, referred to above. Tighten both screws No. 048040 GEB firmly after this adjustment.

The timing of zig-zag mechanism and needle bar in relation to each other can also be achieved with the aid of the timing gauge No. AC 4/36. In the following is given a description of this gauge and its use for timing the above parts.

The timing gauge No. AC 4/36 is a small steel plate « B » (see Fig. 38 with a handle-shaped portion at one end and a V-shaped cut-out at the other end.



Fig. 37

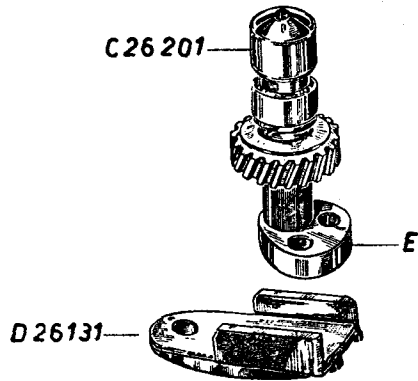

Position I

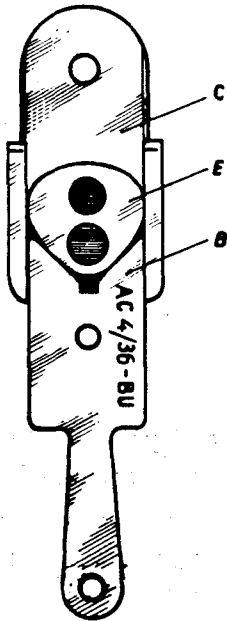

Fig. 38

Position II

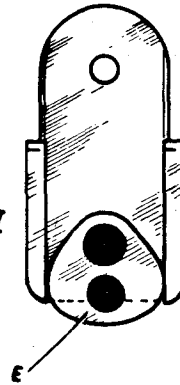
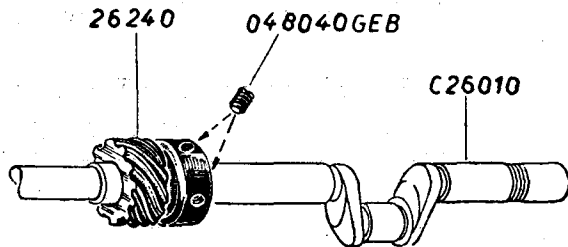

Fig. 39

Fig. 40



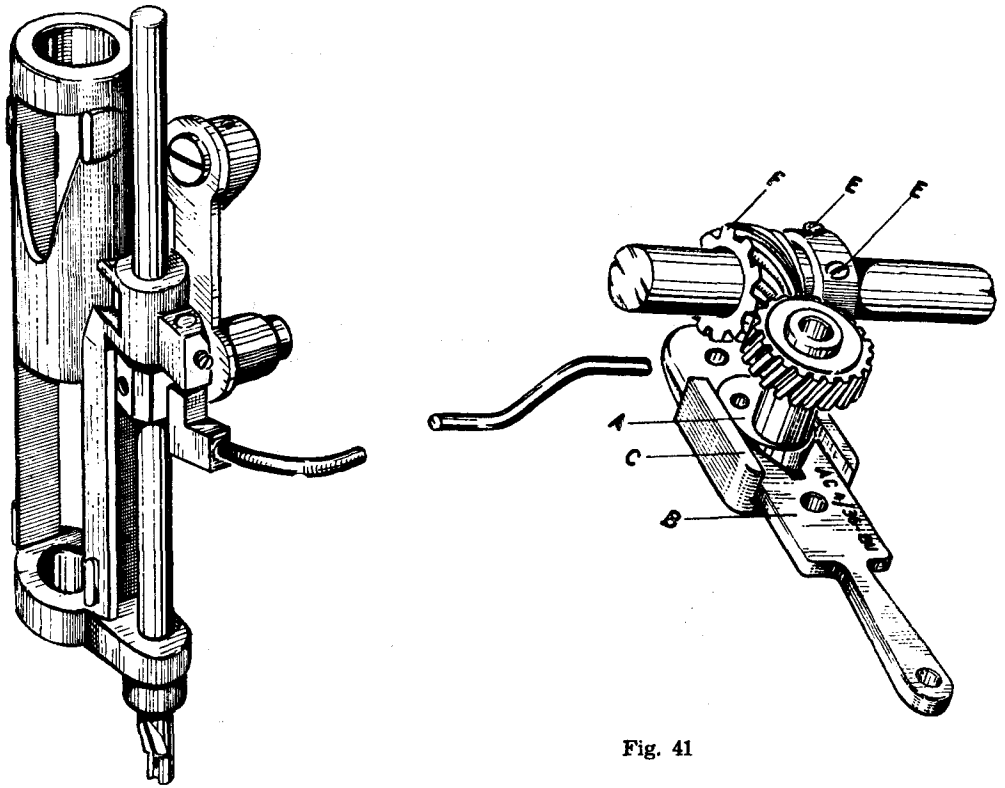

Fig. 41

**Timing procedure.**

1. Turn the balance wheel slowly toward you and bring the eccentric « A » (see Fig. 41) toward the inside of the machine.
2. Insert the timing gauge « B » into the oscillating lever « C » (see Fig. 41) and, while slightly turning the balance wheel back and forth bring the eccentric « A » in a position so that the V-shaped cut-out of the timing gauge « B » fits properly against the back portion of this eccentric.

3. In the position described in the preceding paragraph, the needle bar must be in its *highest position*. If this requirement is not met, adjust as follows:

Loosen the screws « E » of the worm « F » on the arm shaft (see Fig. 41), then, while pressing the timing gauge « B » against the eccentric « A » (to block this eccentric), turn the balance wheel slowly until the needle bar is in its highest position. Finally again, firmly tighten the screws « E » of the worm « F ».

## ***The Feed Dog.***

The purpose of this part is to feed the fabric regularly for a certain distance at every stitch so that the space between one perforation of the fabric by the needle, and the next one, equals the desired length of stitch.

A perfect feeding operation is of great importance for the final result of sewing. An incorrectly operating feed dog will cause irregular feeding of the fabric, unequal length of the stitches, and a seam which is not straight. There are many circumstances which may cause the defects just mentioned.

Before investigating further the causes of incorrect feeding, it is necessary to make certain that the various parts of the feeding mechanism are properly assembled and adjusted and that this mechanism is correctly timed in relation to those groups of parts whose movements are correlated to those of the feeding mechanism. As far as the timing of these movements is concerned, we refer to the chapters of this booklet concerning the corresponding timing procedures. In the following are given instructions pertaining to the correct assembly of the various parts of the feeding mechanism.

The assembly of the parts of the feeding mechanism comprises :

1. The centering of the teeth of the feed dog in the slots provided for them in the needle plate.
2. The adjustment of the maximum protrusion of the feed dog teeth above the top surface of the needle plate.

To make this adjustment, proceed as follows :

- a. Bring the stitch regulating lever No. C 20138 to the « AV » position which gives the maximum forward movement of the feed dog (lever is then in its lowest position).
- b. While turning the balance wheel by hand toward you, check whether the movement of the feed dog in the direction of sewing is correctly centered in relation to the slots of the needle plate : namely, whether the feed dog, in its extreme positions, is equally distanced from the adjacent ends of the feed dog slots in the needle plate. Check also whether the feed dog is correctly centered in the direction

perpendicular to the top surface of the needle plate: namely, whether the tips of the feed dog teeth are alternately at equal distances above and below the top surface of the needle plate during sewing.

c. In case the feed dog is not correctly centered in the direction of sewing, adjust it at the point of connection of the feed dog shaft No. 20100 with the feed dog shaft crank No. 48 (see Figures 42 and 43) in the following manner:

- Loosen the screw No. 048140 FAB which clamps the feed shaft crank No. 48 to the feed dog shaft No. 20100.
- Correct the position of the feed dog by turning the feed dog shaft No. 20100 between its pointed studs No. 20105 and No. 20115 (see Fig. 43) in one direction or the other (as required).
- Firmly tighten the screw which clamps the feed dog shaft crank No. 48 to the feed dog shaft No. 20100.
- Again check whether the feed dog is now correctly centered in the direction of sewing. If necessary, repeat the aforementioned procedure until the feed dog is centered correctly.

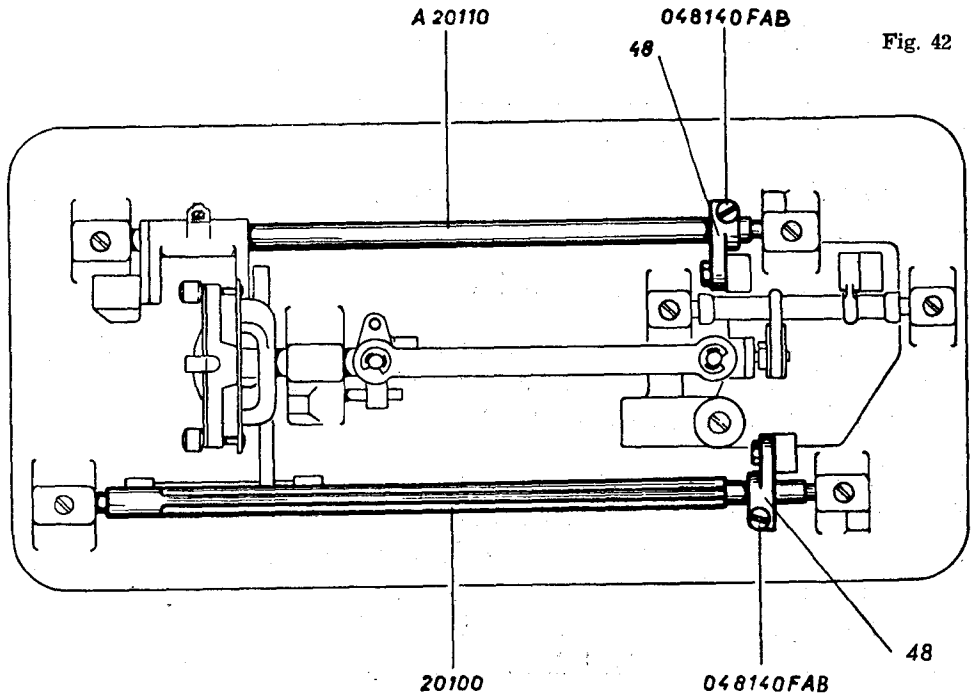

Fig. 42

# ADJUSTING THE MAXIMUM RISE OF THE FEED DOG TEETH ABOVE THE NEEDLE PLATE

## GENERAL RULE

Turn the balance wheel toward you and observe how high the teeth of the feed dog rise above the needle plate.

Adjust the feed dog in such a manner that the full depth of its teeth can be seen above the top surface of the needle plate when the feed dog is at its highest position.

If necessary, adjust the feed dog as follows:

— Loosen the screw No. 048140 FA which clamps the feed dog shaft crank No. 48 to the feed lifting shaft No. D 20110 (see Figures 42 and 44), then turn the feed lifting shaft in the proper direction until the above requirement is met. Tighten the clamping screw in the feed dog shaft crank No. 48 firmly after this adjustment.

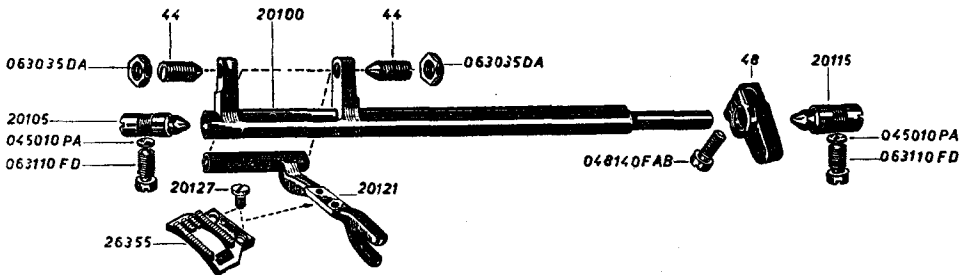

Fig. 43

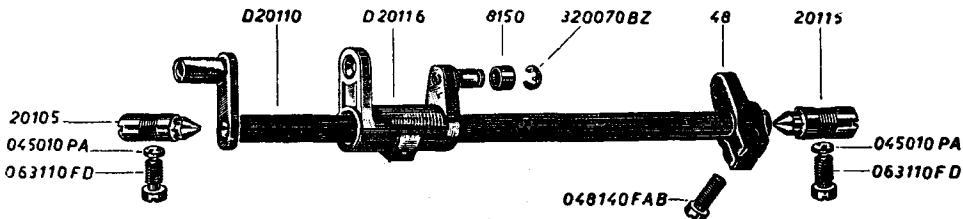

Fig. 44

If the timing gauge No. AC 4/26 (see Fig. 45) is available, use it in the following manner:

- a. Remove presser foot and needle from the machine, then place the timing gauge No. AC 4/26 upon the needle plate, as shown in Figure 45. Turn the balance wheel slowly and check whether the teeth of the feed dog, when in their highest position, are between the two reference faces of this timing gauge (Maximum and Minimum).
- b. If the tips of the feed dog teeth are below the minimum or above the maximum, indicated by the gauge, proceed to adjust the feed dog as follows:

— Loosen the screw which clamps the feed dog shaft crank No. 48 to the feed lifting shaft No. D 20110, then turn the feed lifting shaft

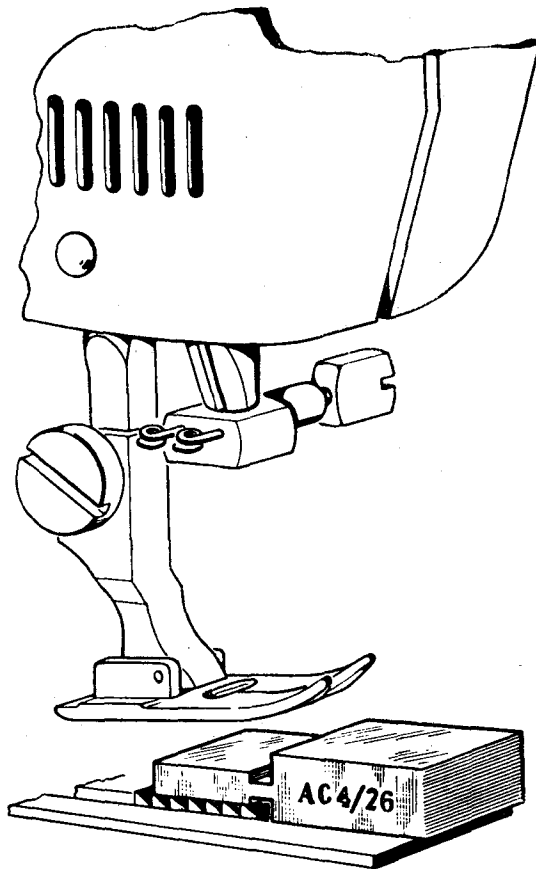

Fig. 45

in the direction required until the feed bar (feed dog bearer) No. 20121 is positioned correctly. Tighten the clamping screw in the feed dog shaft crank No. 48 firmly. Then, while turning the balance wheel slowly toward you and using the timing gauge No. AC 4/26, make certain that the teeth of the feed dog, when in their highest position, are now between the two reference faces of the timing gauge. If necessary, repeat this procedure until the feed dog is adjusted correctly. After the aforementioned adjustment has been taken care of, also check whether the screws No. 20127 which fasten the feed dog to the feed bar No. 20121 (Fig. 43) are firmly tightened.

In case the machine does not yet feed the fabric properly, it will be necessary to check whether the following defects exist:

1. The pressure upon the presser foot is not correctly adjusted.
2. The bottom face of the presser foot does not rest correctly on the teeth of the feed dog.
3. The teeth of the feed dog are worn off to a considerable extent.

To remedy these defects, proceed as follows:

**RE. 1. *Incorrect pressure of the presser foot.***

— Incorrect pressure of the presser foot upon the fabric will have a bad effect on the appearance of the seam. To adjust for the correct pressure, keep the following facts in mind:

- A heavier fabric requires more pressure than a thin fabric.
- Light pressure is required for fine and sheer fabrics so as to prevent damage to the fabric.

**RE. 2. *Bottom face of presser foot rests incorrectly (not flush) on the teeth of the feed dog.***

— To make the machine feed correctly and thus obtain a perfect seam, it is necessary that the entire bottom face of the presser foot rests fully (flush) on all teeth of the feed dog. To check whether this requirement is met, use a thin piece of paper (about .003" thick) in the following manner:

- a. Turn the balance wheel by hand until the feed dog rises to its highest position above the top surface of the needle plate.
- b. Lower the presser foot until it rests on the feed dog.
- c. Lift the presser foot somewhat, then insert the piece of thin paper successively between presser foot and feed dog at each of the four corners of the presser foot, always lowering the presser foot fully after the paper has been inserted.
- d. The presser foot rest properly on the feed dog when the piece of paper is retained firmly between presser foot and feed dog at each of the four corners of the presser foot.

If this requirement is *not* met, it may be due to three different causes. Namely:

- The presser foot, either due to excessive wear or to improper fastening to the presser bar, does not rest correctly on the feed dog.
- The feed dog is either excessively worn or it is not fastened properly in the machine.
- There exists a combination of both aforementioned defects.

To find out whether the presser foot is in perfectly good order, and whether its bottom face is flush and correctly aligned, proceed as follows:

- Firmly tighten the screw which holds the presser foot to the presser bar. Turn the balance wheel by hand until the feed dog is below the needle plate. Then lower the presser foot until it rests on the needle plate. Place a piece of thin paper, successively, under each of the four corners of the presser foot. If the piece of paper is held firmly by each corner of the presser foot, the presser foot is in good condition and does not require any correction. In this case, it then becomes necessary to examine the feed dog.



## TESTING THE FEED DOG

After the presser foot has thus been tested and found to be satisfactory, remove the needle plate and check whether the screws No. 20127 which hold the feed dog to the feed dog bar No. 20121 (see Fig. 43), are properly tightened. If necessary, tighten these screws firmly.

Then lower the presser foot until it rests on the feed dog, and check whether a thin piece of paper is held firmly between presser foot and feed dog at all four corners of the presser foot. If this is not the case, check whether the teeth of the feed dog are worn. A visual inspection of the feed dog, and feeling the sharpness of its teeth by touching them gently, usually is sufficient to determine whether the feed dog is worn to such a degree as to necessitate its replacement with a new feed dog.

If a worn feed dog must be replaced, proceed as follows:

- a. Remove the needle plate.
- b. Remove the worn feed dog.
- c. Attach the new feed dog to the feed bar No. 20121, but do not tighten the feed dog screws completely.
- d. Adjust the feed dog on the feed bar so that its teeth are located centrally within the corresponding slots in the needle plate. If necessary, also adjust the position of the feed bar No. 20121 by means of the pointed bearing screws No. 44 and the lock nuts No. 063035 DA.
- e. Firmly tighten the feed dog screws No. 20127.
- f. Replace the needle plate.

**ATTENTION:** When working on fine and delicate materials such as silk, etc., the teeth of the feed dog must not rise as high above the needle plate as when working on heavier fabrics.

## THE NEEDLE BAR

The adjustment of the needle bar has been explained in the chapter « Timing of Shuttle and Needle Bar ».

The reference lines on the needle bar serves a double purpose:

1. In our factory they help to determine in the yet incompletely assembled machine, the height in the vertical position of the needle bar required for the timing procedure, before the timing gauge No. AC 4/75 has been used.
2. They facilitate the fastening of the needle bar connecting sleeve (No. 20036 in BF or No. 26025 in BU) with the needle bar by means of the needle bar connecting screw No. 24 and the interposed aluminum washer No. 030010 PA (see Fig. 17).

The above method of fastening gives the best guarantee against slipping of the smoothly finished needle bar, since part of the soft washer presses itself into the hollow of the timing mark and thus retains the needle bar in the correct position. For this same reason it is advisable to replace the washer with a new one, or at least turn the old washer to the other side, should it ever become necessary to loosen the connection between the needle bar and the needle bar connecting sleeve. It is then also imperative to reset the needle bar to the correct height.

## THE NEEDLE OF THE MACHINE

To properly select the needle in accordance with the material to be sewn and the thread to be used, and to insert the needle correctly, consult the corresponding pages of the instruction book furnished with the machine.

The following requirements must be met:

a. The needle must have a sharp point to prevent tearing of the material during sewing. Sewing with a needle which has a blunt point is usually accompanied by a knocking noise of the blunt needle, penetrating and tearing the material.

b. The needle must be straight. A bent needle will cause a lot of trouble, depending upon the degree to which it is bent. A straight needle will pass exactly through the center of the stitch hole in the needle plate.

A bent needle may strike the edge of the stitch hole in the needle plate and break, or it may damage the edge of the stitch hole. A needle bent toward the right, may interfere with the oscillating shuttle and break, or it may damage the shuttle. A needle, bent toward the left, may cause skip stitches since the distance between the needle and the oscillating shuttle has become too large, and the point of the shuttle, therefore, cannot catch the loop of needle thread.

The aforementioned troubles will become more evident while sewing heavy materials, with the possibility of frequently breaking the needle or skip stitching (the latter due to the fact that the shuttle cannot catch the loop of the needle thread). Therefore, when a bent needle is the cause of these troubles, it is best to replace the old needle with a new one.

There are still two possibilities of trouble in connection with the needle. Namely:

1. The needle is straight, but when inserted in the machine, shows an inclined position and does not stitch perpendicularly through the fabric. This is due to the fact that the lower end of the needle bar is bent. In this case it is necessary to straighten lower end of the needle bar, or else to replace the bent bar with a new one.

2. The eye of the needle is sharp and breaks the thread. Such a defective needle must be replaced with a new one. To give the needle a firm grip in the needle bar, tighten the screw in the needle clamp with a screw driver rather than by hand.

## PRESSURE ADJUSTMENT OF THE PRESSER FOOT

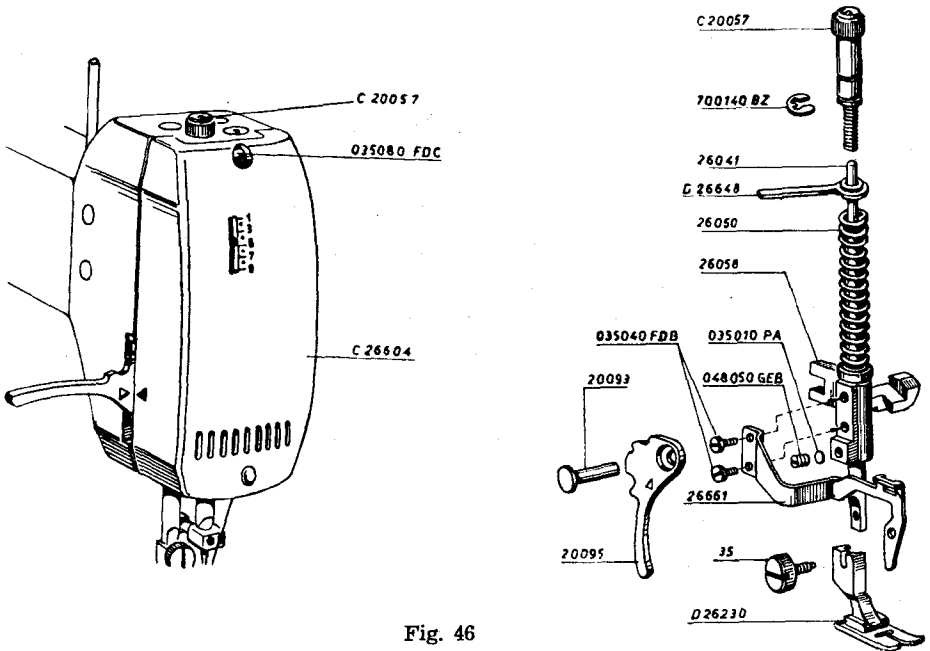

Fig. 46

The pressure is controlled with the aid of the pressure regulating thumb screw No. C 20057 (see Fig. 46).

By loosening the pressure regulating thumb screw, the pressure of the presser foot can be released. Make certain that the presser foot always exerts a certain pressure upon the fabric.

The pressure upon the fabric increases gradually as the pressure regulating thumb screw is turned down.

The numbered scale in front of the face plate (No. D 20276 on BF Nova; No. C 21776 on BF Mira; No. D 26404 on BU Nova; and No. D 26604 on BU Mira), in connection with the presser bar index pin No. 26048, on Nova series and No. D 26648 on Mira series, indicates

the pressure exerted at the moment, by the presser bar spring No. 26050 upon the presser foot. In this connection it should be mentioned that there is a well defined though loose interdependence between the pressure imposed by the presser bar spring and the tensions of the upper and lower thread. Namely:

— While for the type of fabric in work, the tension of the lower thread must be kept constant, the pressure of the presser bar spring and the tension of the upper thread must be changed in accordance with the thickness of the type of fabric.

## **POSITIONING OF PRESSER BAR AND PRESSER FOOT**

The opening in the presser foot (hole or slot), which permits the passage of the needle, must be adjusted so that it is exactly above the corresponding opening in the needle plate.

Should the presser foot not be positioned correctly, proceed as follows:

- a. Loosen the presser bar screw No. 048050 GEB slightly in the presser bar guide No. 26058 (see Fig. 46).
- b. Turn the presser foot until it has the correct position on the needle plate.
- c. Tighten the aforementioned screw firmly, first making sure that the presser bar guide No. 26058 has not shifted upward or downward from its original position, since this would bring with it a change of the pressure and the vertical position of the presser foot.

## ***Height of Presser Foot.***

(Position in vertical direction)

The presser bar lever No. 20095 (see Fig. 46) permits three different positions of the presser foot:

### ***1. The presser bar lever is entirely down.***

In this instance, the presser foot rests firmly upon the needle plate (or, upon the feed dog) and there is some space between the presser bar lever and the presser bar guide above.

### ***2. The presser bar lever is partially raised*** (see Fig. 46).

This is the intermediate (or embroidery) position. In this position, a white triangle in the presser bar lever lines up with a horizontal timing mark on the face plate (No. D 20276 on BF Nova; No. C 21776 on BF Mira; No. D 26604 on BU Mira; and No. D 26404 on BU Nova). With the lever in this position, the presser foot is kept raised just sufficiently high to permit the passage of the embroidery hoop below it, while the tension of the upper thread remains unchanged.

### ***3. The presser bar lever is raised completely.***

In this instance, the presser foot does not rest upon the needle plate (or the feed dog) and both tension discs No. 20681 are separated from each other (the upper thread is under no tension). In this position of the presser bar lever, the bottom face of the presser foot should be about 1/4" above the needle plate in the BF machine, and about 9/32" in the BU machine.

## TENSION OF THE UPPER THREAD

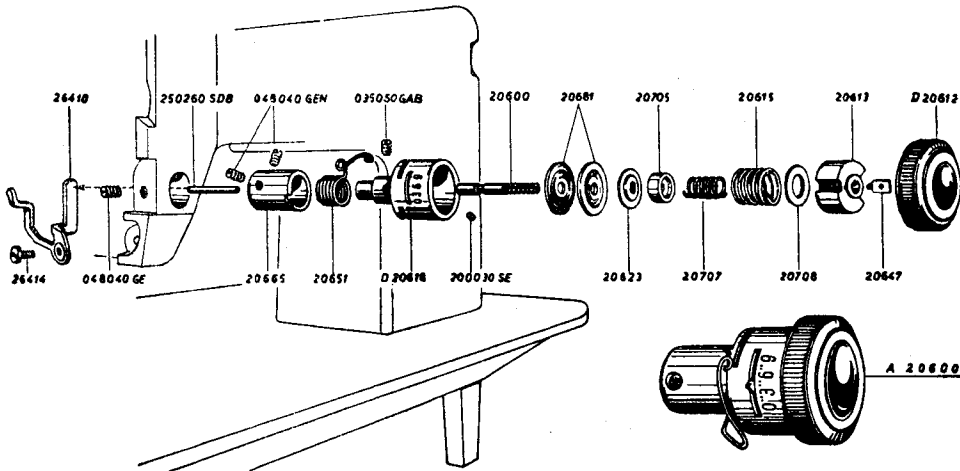

Fig. 47

Correct adjustment of the upper thread tension is imperative for good sewing.

To function properly, the tension discs No. 20681 (see Fig. 47) must be kept very clean. It is not advisable to clean dirty tension discs quickly by simply inserting a rag between them. Such a procedure may shift the dirt to some hidden spot in the tension mechanism and cause the tension discs to get out of contact with each other. This occurrence, of course, will disturb the tension of the upper thread and make sewing impossible.

To clean the upper thread tension thoroughly, the knotted nylon thread furnished with the machine can be used; the instructions given in the Instruction Booklet should be followed.

Nevertheless in order to examine the upper thread tension thoroughly, we suggest that you remove the entire thread tension mechanism from the machine by unscrewing the thread tension knob No. D 20612 first, and then removing successively all other parts of this mech-

anism. All these parts shall be cleaned thoroughly in a pan filled with cleaning fluid, and then be wiped dry. Every part must be examined thoroughly with regard to possible defects. The tension discs must not have rust spots on their contact faces, or deep grooves worn into them by the thread.

Defective tension discs must be corrected, if possible. Place the contact faces of such repaired discs together, and check whether they touch each other fully. If the tension discs, or any other part of the tension mechanism, are defective beyond repair, replace them with new parts. After having cleaned and examined all parts of the tension mechanism, replace them in their original positions. Then adjust the pressure upon the tension discs until the correct tension has been obtained.

If, during sewing, the tension of the upper thread gradually becomes weaker, it can be assumed that, due to vibrations of the machine, the thread tension knob No. D 20612 has become loose. To remedy, place the blade of a screwdriver into the slot of the tension stud No. 20600 and spread both halves of the tension stud slightly.

### ***The Thread Take-Up Spring (Check Spring) of the Upper Tension.***

This check spring No. 20651 (Fig. 47) serves two purposes. Namely:

1. To take up and hold the slack of the upper thread, given free by the descending thread take-up lever (No. D 20033), until the eye of the descending needle has entered the fabric.
2. To release gently the thread which, during the finishing phase of the stitch, was required for the stitch formation, and to permit the thread take-up lever to close the stitch without tearing the fabric. When released, the check spring must occupy the position as shown in Figure 48; and the loop of this spring must include an angle with the vertical center line of the tension adjusting knob, as indicated in this illustration.



If the check spring fails to function, the slack of the upper thread will not be taken up. The excessive length of thread may then clog the stitch hole in the needle plate, wrap itself around the needle, or cause irregular stitches. The thread may also place itself in the way of the descending needle and thus be damaged by the point of the needle.

If the check spring, when released, occupies a different position than the one indicated above, adjust the spring as follows:

1. Remove the face plate (No. D 20276 on BF Nova; No. C 21776 on BF Mira; No. D 26404 on BU Nova; and No. D 26604 on BU Mira) of the machine.

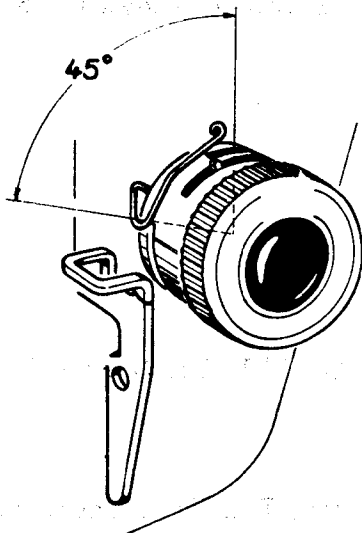

Fig. 48

2. Loosen the screw No. 048050 GEN which holds the tension mechanism in the arm of the machine.

3. Turn the tension pin holder No. 20665 and with it the tension mechanism, until the check spring occupies its correct position.

4. Fix the tension mechanism in its new position by tightening the screw firmly which holds the tension mechanism to the arm of the machine.

## **TENSION OF THE LOWER THREAD (TENSION OF THE BOBBIN CASE)**

The tension spring No. 20178 on the bobbin case No. D 20176 (see Fig. 49) must place the lower thread under maximum tension when the bobbin case tension spring screw No. 20179 is completely tightened. This tension will gradually decrease when the tension spring screw is loosened. The lower thread must always be under some tension until the screw No. 20179 is completely loosened. The tension of the lower thread must remain uniform for any particular position of the adjusting screw No. 20179 and must not change while the screw remains in this position. Figure 49 shows the bobbin case in a disassembled condition.

## **THE OSCILLATING SHUTTLE**

The shuttle No. 26237 (see Fig. 50) is set in motion by the shuttle carrier No. D 26340) with the intermediate aid of the shuttle carrier adjusting spring No. 20194, and it retains its position in the race body No. D 26330 by means of the race cover No. 26333. The race cover is connected at its lower portion with the race body by means of a ring-shaped hook No. 26339, and is held against No. D 26330, the race body, with the aid of two knobs No. 26337. These knobs are under spring pressure, and thus press the race cover against the race body. By pulling both knobs away from the race cover and swinging them sideways, the race cover can be swung away from the race body, whereby the race cover will turn around the aforementioned ring-shaped hook. The shuttle then can be removed easily from the race

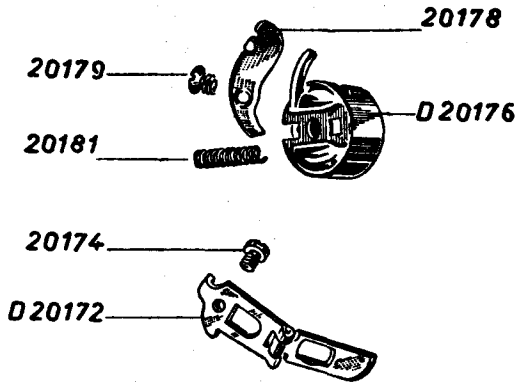

Fig. 49

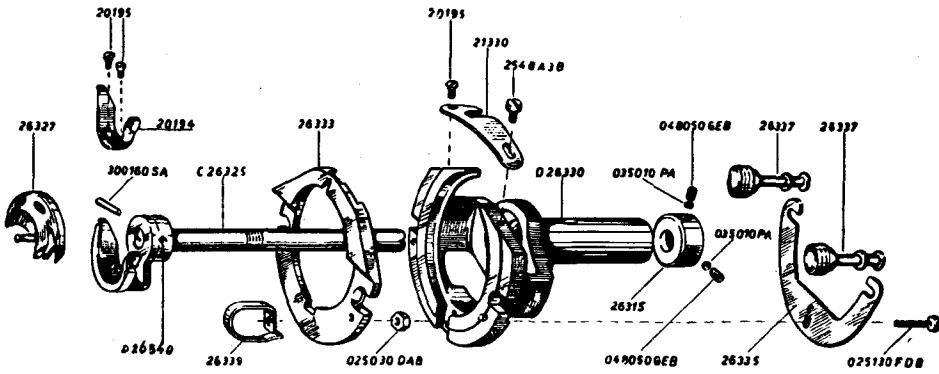

Fig. 50

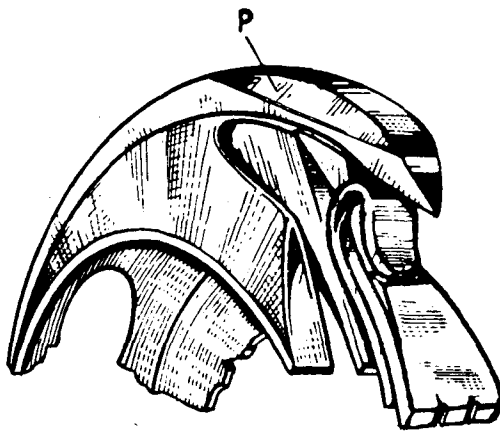

Fig. 51

body. When assembled with the race body, the race cover must yieldingly press against the race body. This will prevent the shuttle from jamming should pieces of thread, dirt, etc. get between shuttle and race body while the machine is in motion.

To keep the machine in good order, it is essential to clean the shuttle (as well as all other vital parts of the stitch mechanism) frequently and thoroughly, and to remove all dirt, lint, and pieces of thread which may have accumulated in the machine. Remove also any residues (gummed oil) caused by the use of improper lubricant.

The same care must be applied to the raceway in the race body, and to the race cover. They must be cleaned frequently and thoroughly. It is also essential to keep the vertical groove (channel) in the lower portion of the race body, which serves to let any dirt, etc. escape from the race body, free and clean.

A space of about .012" between the shuttle and shuttle carrier spring No. 20194 is required for the passage of the thread.

Too much play between shuttle and shuttle carrier regulating spring will cause excessive noise and will influence the timing of the oscillating shuttle.

To overcome the aforementioned defects, it will be necessary to tighten the fastening screws No. 20195 securely. If the shuttle carrier spring is damaged, replace it with a new spring.

It is also advisable to check from time to time, whether the shuttle is still timed correctly.

Furthermore, also check whether the point of the shuttle has been blunted, or whether those portions of the shuttle over which the thread passes, have become rough due to rust or corrosion.

Moreover, it is also essential to check whether the inclined portion « P » of the shuttle (« needle guard » — see Fig. 51) has been damaged (nicked) by a bent needle. Should this have happened, it will be necessary to repair this damaged portion by smoothing it with fine emery cloth, and polishing it with crocus cloth or on a buffing wheel afterwards.

The shuttle will work properly after this correction.

## THE BOBBIN CASE

The bobbin case (see Fig. 49) serves a dual purpose. Namely:

- a. It contains the bobbin with the lower thread.
- b. It is assembled with the spring for adjusting the tension of the lower thread.

The bobbin case is kept in its correct *angular* position in the machine by means of the finger-shaped prong which extends into a corresponding notch of the shuttle race cover. The prong has just sufficient play in the notch to let the heaviest thread pass freely when the upper thread is pulled up by the thread take-up lever.

In *axial* direction, the bobbin case is retained securely on the post of the oscillating shuttle by means of the bobbin case latch lever No. D 20172. Bobbin case latch and bobbin case latch lever are hinged together at one end. The bobbin case latch is always under pressure of a small spring No. 20181, inside of the bobbin case, which forces part of the bobbin case latch into the annular groove at the free end of the post of the shuttle and thus retains the bobbin case securely on this post. The free end of the bobbin case latch is shaped in the form of a hook. By lifting the bobbin case latch lever, the bobbin case latch is withdrawn, and the bobbin case can then be removed from the post of the oscillating shuttle. Simultaneously, the hook-shaped end of the bobbin case latch will grip underneath the adjacent flange of the bobbin, thus taking the bobbin with it and holding it as long as the latch lever is lifted.

## THE BOBBIN

Disregarding the material it is made of, it is always imperative that the bobbin No. D 140 (see Fig. 52) fits properly in the bobbin case and revolves in it freely. There must be no friction between the flanges of the bobbin and the inside of bobbin case and shuttle.



Fig. 52

## THE STITCH REGULATOR

This comprises the entire mechanism which controls the length of stitch of the machine.

The length of stitch is adjusted by means of hand lever No. C 20138 (see Fig. 53) which protrudes from a slot in the upright portion of the machine arm.

On the stitch regulating plate No. D 21075 (see Fig. 54) which surrounds the above hand lever, are numbers which indicate the various lengths of stitches in inches and millimeters. This plate also bears the markings « FO » and « AV » (for Forward Sewing) and « RE » and « IN » (for *Reverse Sewing*). The feeding of the fabric in the desired direction is obtained by moving the hand lever No. C 20138 downward from « O » for forward sewing, or upward from « O » for reverse sewing, whereby the movable indicators No. 21081 and No. 21086 point out the length of stitch at the respective position of the hand lever No. C 20138.

The machine will not feed the fabric when the upper indicator No. 21081 points at the number « 0 » (zero) of the aforementioned stitch regulating plate.

By pushing the stitch regulating lever No. C 20138 downward or upward, the stitch regulating indicators will move in directions opposite to each other in the slot of the stitch regulating plate.

If it is desired to sew forward and backward with the same length of stitch, push the stitch regulating lever downward until the upper stitch regulating indicator points at the stitch length required. Then firmly tighten the stitch regulating stop screw No. 21095 (Fig. 54) below the slot in the stitch regulating plate.

By moving the stitch regulating lever evenly downward and upward in the free space between the now fixed stitch regulating indicators,

it is possible to sew forward and backward with the same length of stitch.

The causes of any defects in the stitch regulating mechanism can be easily discovered and eliminated, as pointed out below.

These defects are:

**1. The stitch regulating indicators do not move.**

To remedy, proceed as follows (see Fig. 54):

a. Push the stitch regulating lever No. C 20138 downward until the stitch regulating indicators move to the positions of the greatest stitch length.

b. Fix these extreme positions of the stitch regulating indicators by tightening the stitch regulating stop screw No. 21095. Then move the stitch regulating lever to « 0 ».

c. Loosen and remove the set screws No. 26413 (Fig. 53), which hold the stitch regulating plate No. D 21075 to the machine arm. Then turn this plate 90 degrees, and remove it by slipping it over the stitch regulating lever.

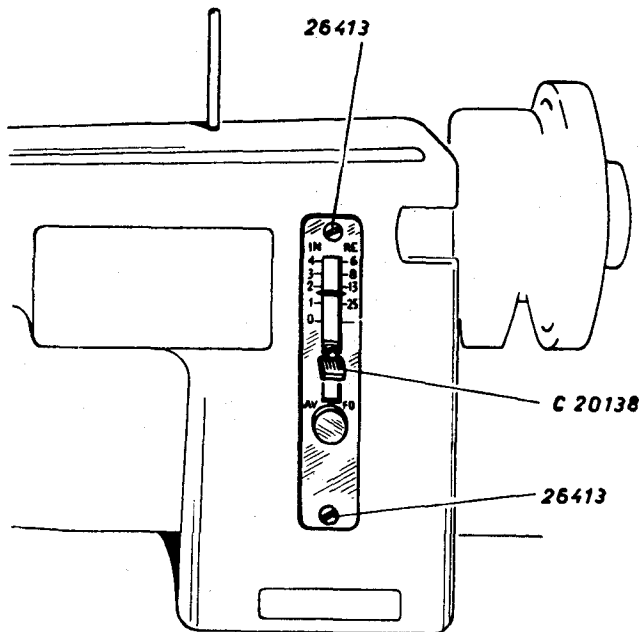

Fig. 53

d. Examine the gear drive and the rack portions of the stitch regulating indicators which are located at the back of the stitch regulating plate.

e. Check whether the screw No. 025030 FDCP, when tightened, holds the entire assembly firmly, and whether the locating pin, at the back of the stitch regulating plate, is inside the slot of the stitch regulating mechanism support No. 21090.

f. Carefully clean all parts of the stitch regulating indicator mechanism, making sure that no substances like dirt, lint, etc., remain which would interfere with the proper function of these parts.

g. Replace all parts as they were mounted on the machine previously.

After a long time of use the teeth of the small gear, as well as those of the two racks, may wear out. As a result these parts become loose and will not work anymore with the desired accuracy. To remedy this defect, bend the free ends of both racks somewhat towards each other (by means of a tweezers or small pliers) until the looseness between gear and racks has disappeared.

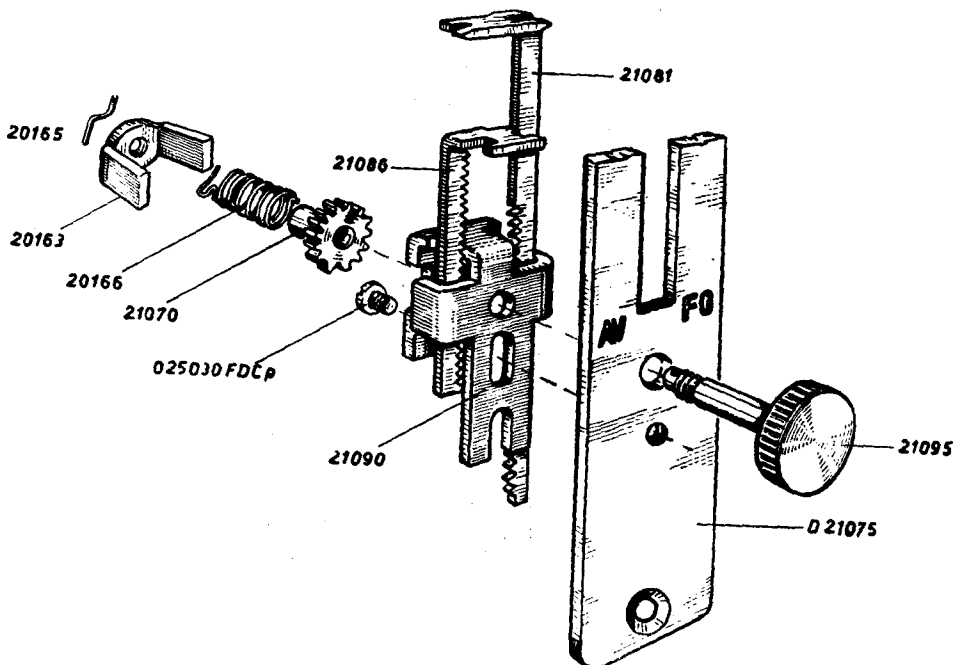

Fig. 54



**2. *The length of stitch during forward sewing is not the same as that during reverse sewing.***

In this case, which occurs rarely, remedy can be obtained as follows (see Fig. 54).

Remove the stitch regulating plate No. D 21075. Then adjust the position of the rack portions of both stitch regulating indicators No. 21081 and No. 21086 in relation to each other, so that both indicators arrive at the extreme ends of the slot in the stitch regulating plate at the same moment.

**THE BOBBIN WINDER MECHANISM  
(FOR BF AND BU MACHINES)**

This mechanism serves the purpose of refilling the empty bobbin with the necessary thread. The machine must not sew while the bobbin is being filled. The mechanism functions rather simply and is easy to operate. To make certain that the Bobbin Winder is in good condition, check whether the following requirements are met:

1. The rubber ring No. 20420 of the bobbin winder (see Fig. 55) must, in its working position, touch the rim of the balance wheel with just sufficient pressure so as to be taken along by the revolving balance wheel. The rubber ring will thus also cause rotation of the bobbin winder pulley and the bobbin winder spindle No. D 21138 which are firmly assembled with each other.

2. The curved end of the bobbin winder latch No. 21166 which presses upon and guides the layers of thread while the bobbin is being filled, must automatically release the bobbin winder before the bobbin is filled completely.

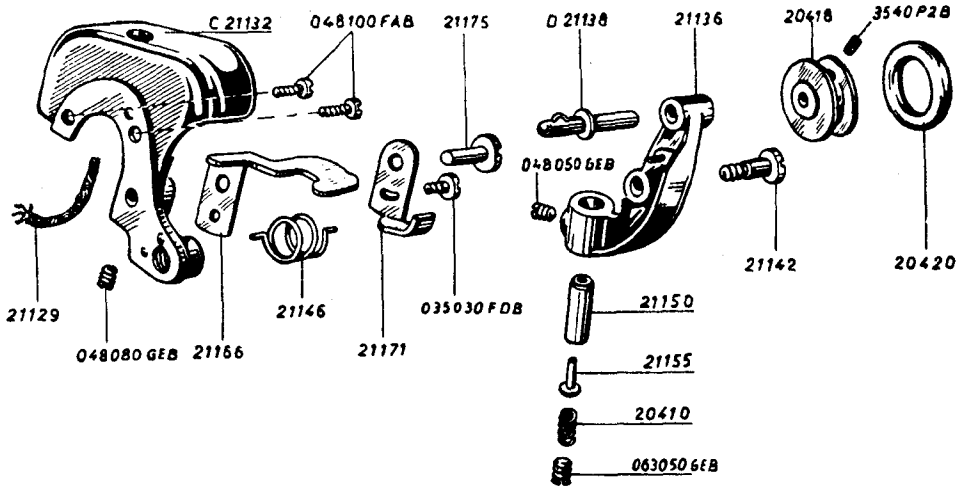

Fig. 55

3. The small spring, inserted in the bobbin winder spindle No. D 21138, must fully enter the slot at the hole of the bobbin in order to carry the bobbin with it while revolving.

4. The thread must fill the bobbin uniformly in even layers which form a cylindrical shape around the bobbin.

To repair any part of the bobbin winder mechanism, first remove the balance wheel No. 20399 in the following manner (see Fig. 56):

- a. Loosen the stop screw No. 20683.
- b. Unscrew and remove the stop motion clamp screw No. 21210.
- c. Remove the stop motion clamp washer No. 26012 and the balance wheel.

If, after the balance wheel has been taken off, the removal of the complete bobbin winder is required, turn the balance disc bushing No. D 20395 and bring the hole in the balance disc portion successively in line with the screws No. 048100 FAB (see Fig. 55) by means of which the bobbin winder frame No. C 21132 (see Fig. 55) is attached to the arm of the machine. By inserting a screw driver through the aforementioned hole in the balance disc bushing, these screws can be removed and the bobbin winder mechanism be taken off the machine. In the rare case when it becomes

necessary to remove the balance disc bushing No. D 20395, care must be taken to replace this bushing in exactly the same position in which it was mounted on the upper shaft No. C 26010 previously. Otherwise the machine would get out of balance and vibrate excessively. In this respect, it should be kept in mind that the pointed fastening screw No. 063130 GDB in the balance disc bushing must always enter the corresponding groove in the upper shaft No. C 26010. To prevent errors, it is advisable always to leave the screws Nos. 063100 GEB and 063130 GDB in their component holes in the balance disc bushing No. D 20395.

It is important, occasionally, to check and clean all parts of the bobbin winder mechanism to prevent these parts from moving sluggishly or becoming tight. The springs, which cause the movements of these parts, must not become clogged with lint and dirt, and should, therefore, be cleaned from time to time.

To regulate the amount of thread to be wound on the bobbin, and to adjust the position of the bobbin winder pulley, it is necessary to change, as required, the angular position of the winder check plate No. 21171 in relation to the winder thread guide plate No. 21166 (see Fig. 55).

If the thread is not wound uniformly on the bobbin, adjust the position of the small thread tension device No. A 20430 (see Fig. 57) on the bed plate of the machine in such a manner that the thread, leaving the small tension device, runs up perpendicularly to the center of the winder thread guide plate (respectively, to the center of the bobbin to be filled with this thread).

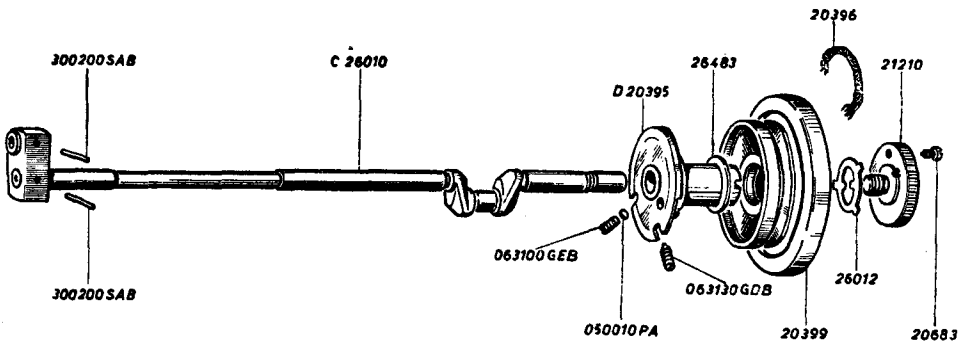

Fig. 56

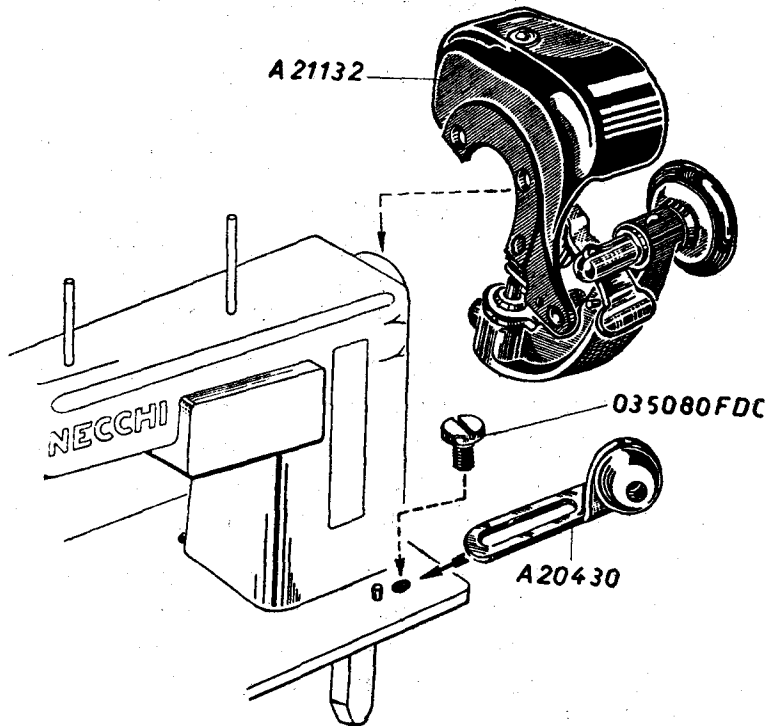

Fig. 57

### THE ZIG-ZAG STITCH MECHANISM

This mechanism serves the purpose of setting in motion the needle bar support No. D 26030 (see Fig. 60) in unison with the race body No. D 26330, and thus to make possible those coordinated movements of the needle and the shuttle No. 26327 which are required to perform the zig-zag seam. The zig-zag seam can be performed in several varieties in accordance with the positions of the various parts which are used for adjusting the zig-zag stitch as is indicated in Fig. 58.

POSITION OF NEEDLE DISPLACEMENT LEVER

LEFT

CENTER

RIGHT



Position of zig-zag stitch from 0 to 5

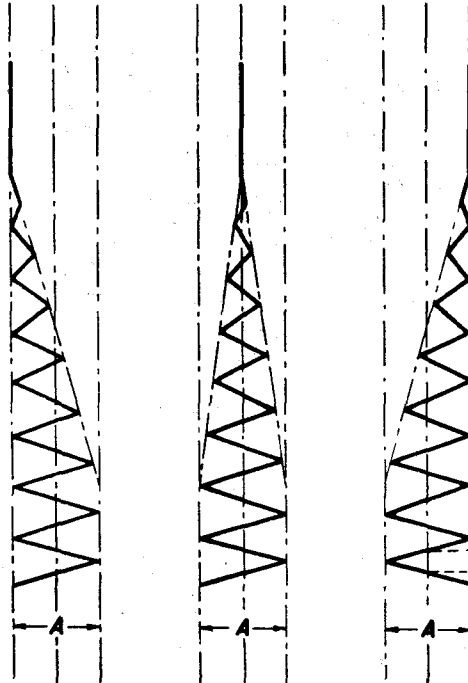
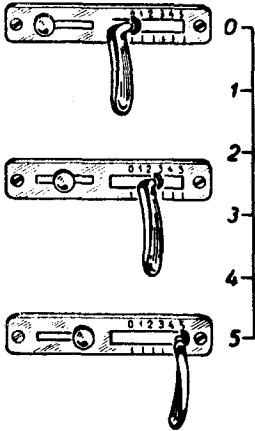

Stitch length regulating lever



Above diagram shows the location and the variations of the zig-zag stitch at the various positions of the needle displacement lever and the zig-zag stitch lever.

"A" indicates the maximum width of the zig-zag stitch.

Fig. 58

### ***Upper group of the zig-zag Mechanism.***

To disassemble the group of parts which induce the swinging movement of the needle bar support No. D 26030, proceed as follows:

1. Remove the face plate (No. D 26404 on BU Nova and No. D 26604 on BU Mira) and the zig-zag stitch regulating plate No. A 26186 (Fig. 59) by loosening the screws No. 26413.
2. Remove the back plate No. 26188 of arm.

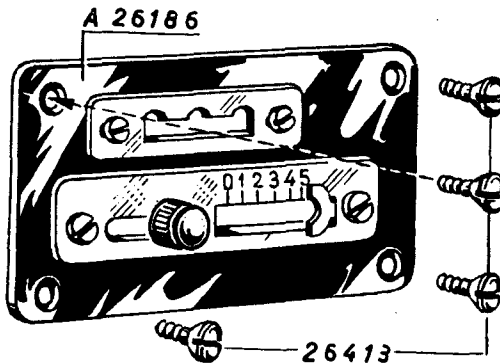

Fig. 59

3. Disassemble the needle bar drive in the following manner (Figure 60):

- a. Loosen the screw No. 035050 GAB which holds the pin No. 26075 in the needle bar support No. D 26030.
  - b. Remove the snap ring No. 230060 BZ which holds the pin No. 26075.
  - c. Remove the pin No. 26075 by pushing it upwards.
  - d. Loosen the screw No. 048080 FAB by means of which the actuating rod No. D 26070 is held in the connection No. 26081.
  - e. Remove the actuating rod No. D 26070 by pulling it out of the machine from the face plate side.
4. Remove the snap ring No. 500110 BZ on the connecting rod pin No. 26085 and lift the connection No. 26081 out of the machine.
  5. Loosen the screw No. 26111 in the zig-zag regulating lever No. 26110 and remove the zig-zag stitch control lever No. 26121.

6. Turn the zig-zag regulating lever No. 26110 towards the right until the movement sector No. 26106 comes out of the channel (groove) at the underside of the oscillating lever No. D 26131 (Fig. 61).
7. Now the entire group, which is composed of the vertical shaft No. D 26255, the zig-zag movement connecting rods No. C 26095 and No. D 26250, and the zig-zag movement connecting rod pin No. 26085 may be disassembled (see Fig. 60). Proceed as follows:
  - a. Remove the screw No. 035050 GAB at the lowest end of the vertical shaft and pull out the shuttle bearer removal rod pin No. 20149 which connects the race body carrier connecting rod No. D 26275 with the vertical shaft No. D 26255.

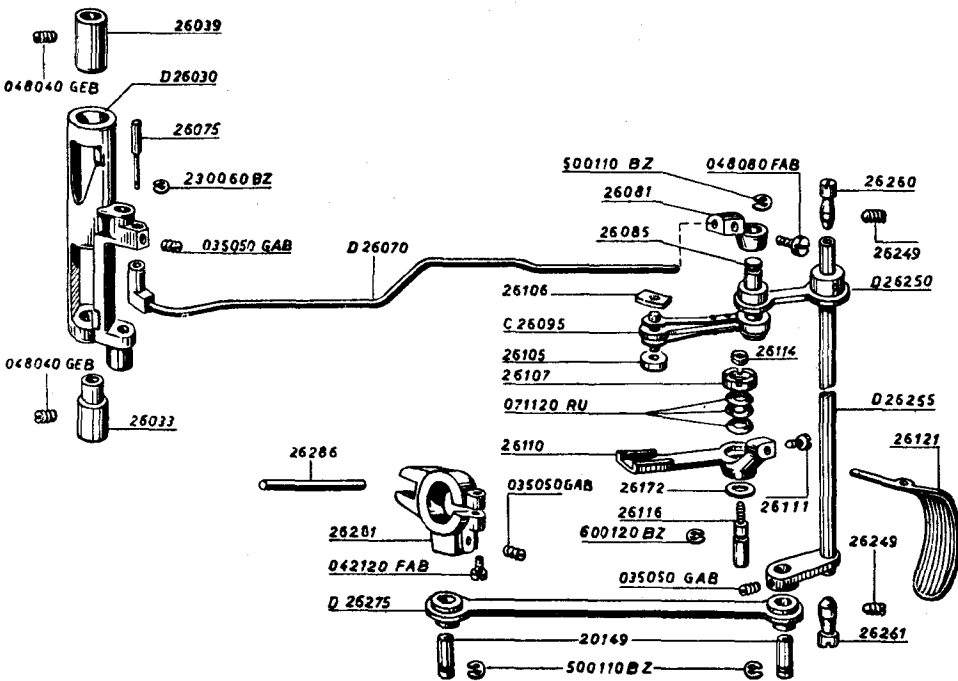

Fig. 60

- b. Pull out the pointed pin No. 26261 at the lower end of the vertical shaft No. D 26255.
- c. Remove the connecting rod No. A 26345 of the feed dog from the machine.
- d. From underneath the bed plate, remove the entire group No. D 26255 of the vertical shaft. To perform this operation, swing out the connecting rods No. C 26095 and No. D 26250, arran-

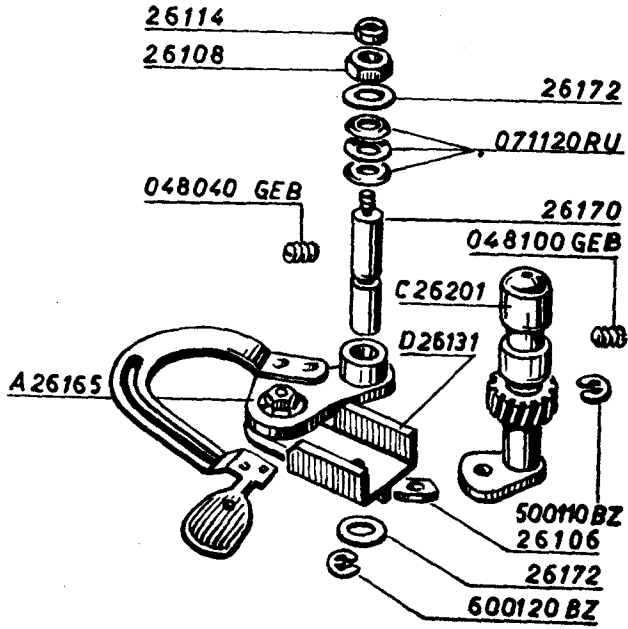

Fig. 61

ged upon each other, and move the rock shaft No. 21230 by turning the balance wheel in order to facilitate the removal of the entire group of the vertical shaft.

8. To disassemble the zig-zag regulating lever No. 26110 (Fig. 60), it is necessary to push the complete oiler No. D 21260 (Fig. 66), which is just above the pin No. 26116, out of the arm of the machine. This is done by means of a curved punch (Fig. 65). Now, introduce the special screw driver (Fig. 63) into the empty hole and loosen the retaining ring No. 26114; then, using the perforated ring (Fig. 64), loosen also the washer No. 26107 (see also Fig. 67). Lift the lever No. 26110 out of the pin No. 26116 which is forced into the arm of the machine; at the same time, remove the three washers No. 071120 RU.

When reassembling this group, make sure to arrange the three elastic washers No. 071120 RU as shown in Figure 68; furthermore in order to avoid an extra adjusting operation, adjust, as explained in paragraph 6 on page 38, the ring No. 26114 and the friction washer No. 26107 in such a way that the zig-zag regulating lever No. 26110 is not too hard (nor too loose) to turn by hand.

9. To disassemble the group A 26165 of the needle displacement lever proceed as follows (Fig. 61):



a. Remove the vertical shaft enclosure cap. No. 26481 from the arm of the machine with the curver punch (Figs. 65 and 69).

b. Into this opening, place the special screwdriver (Fig. 63) on the head of the stop washer No. 26114. Loosen the stop washer No. 26114. Then, with the above mentioned perforated ring (for the machines up to serial No. 449394) or with a common wrench (for the other machines) loosen the friction regulating washer No. 26108.

c. Loosen the screw No. 048040 GEB (Fig. 61) which holds the needle displacement lever pin No. 26170 in the arm of the machine.

d. Remove the snap ring No. 600120 BZ on pin No. 26170.

e. Remove the needle displacement lever pin No. 26170 by pushing it downwards and out of the machine.

f. Remove the entire needle displacement lever No. A 26165.

In reassembling this group make sure to replace the three elastic washers No. 071120 RU and the washer 26172 (Fig. 61) on the pin No. 26170 in the order shown in Figure 61.

10. After removal of lever No. A 26165, remove gear and eccentric assembly No. C 26201 as follows (Fig. 61):

a. Remove the screw No. 048100 GEN (Fig. 61) which is located in the front face of the machine arm.

b. With a soft punch (wood or brass) gently push down the assembly No. C 26201 and remove it through the front opening in the arm.

The above explanations constitute the entire disassembly of the upper group of the zig-zag mechanism. In the following paragraphs are discussed the disturbances which may occur in this upper group of the zig-zag mechanism.

1. The needle bar is not centered in the stitch hole of needle plate when the needle displacement lever No. C 26165 (Fig. 62) is in its center position and the zig-zag control lever No. 26121 (Fig. 60) is at zero (completely towards the left).

In this instance, it is necessary to make an adjustment with the aid of the actuating rod No. D 26070 (Fig. 60). Remove the zig-zag

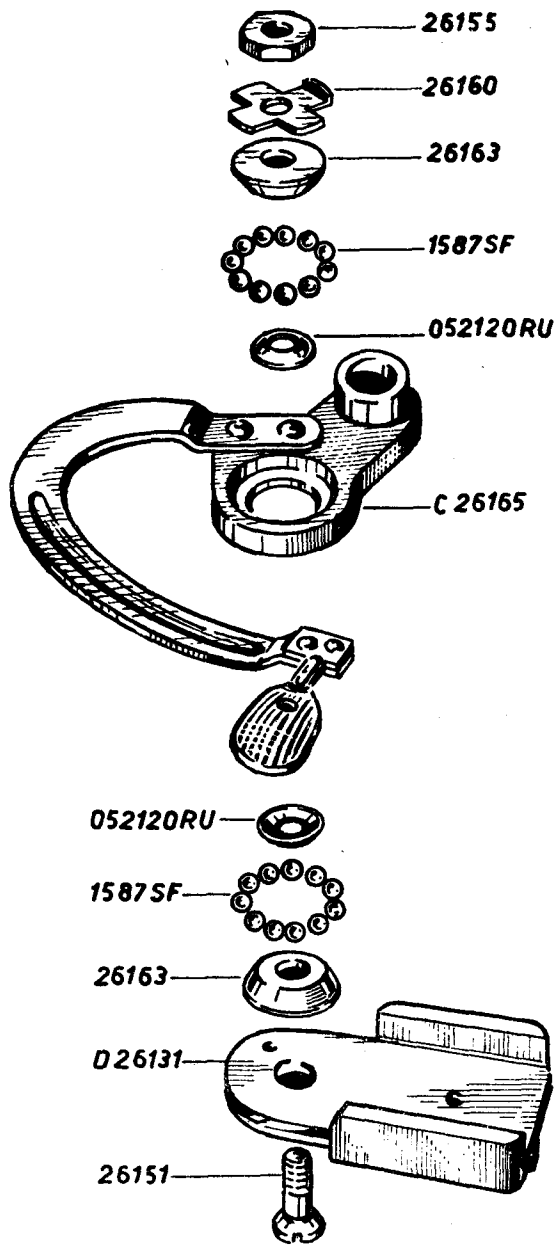

Fig. 62

stitch regulating plate No. A 26186 (Fig. 59) by loosening the four screws No. 26413 making certain not to move the needle displacement lever No. C 26165. Then loosen the screw No. 048080 FAB in the connection No. 26081 (see Fig. 60), adjust the actuating rod No. D 26070, as required, and tighten the screw No. 048080 FAB again. After this has been done, check whether needle and oscillating shuttle are correctly timed in relation to each other. If necessary, correct the position of the shuttle in relation to the needle (see adjustment III on page 13).

2. The machine runs *noisily* while sewing zig-zag.

If the cause of the noise is located somewhere in the upper group of the zig-zag mechanism, it is advisable to check all connections between the various parts of this group with regard to looseness due to wear or improper assembly. Disassemble this group of the



Fig. 63



Fig. 64



Fig. 65

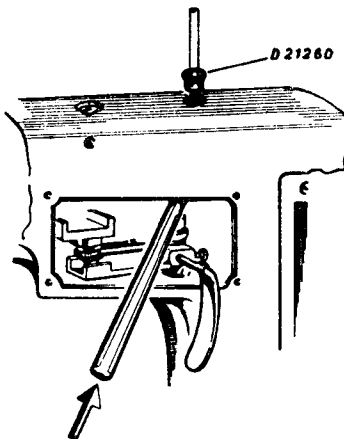

Fig. 66

zig-zag mechanism, as explained previously, and check whether and where excessive looseness occurs; check especially the fit of the movement sector No. 26106, and of the movement roller No. 26105 (see Fig. 60) in their component parts. If necessary, replace old parts with new ones.

3. Noisy zig-zag sewing due to looseness somewhere in the oscillating lever No. A 26165 (see Fig. 61).

Disassemble all parts, as explained previously. Then check and find whether the looseness is due to:

a. imperfect assembly or fit of the ball bearing which supports the oscillating lever No. D 26131 (see Fig. 62). This disturbances should never happen since the use of the spring washers does not allow any play;

b. excessive wear in the lower channels of this lever No. D 26131. Check instance (a) as follows:

With a screw driver open the bent-up wing of the washer No. 26160 (Fig. 62). Check the looseness of the ball bearing and take up any excessive looseness by tightening the nut No. 26155, making certain, however, that the needle displacement lever No. C 26165 (Fig. 62) does not operate too hard.

Bend up again the stop wing of the washer No. 26160 which prevents the nut No. 26155 from getting loose.

If, after this adjustment of the ball bearing, the machine tends to turn heavily or to bind, do not proceed to sew. Disassemble the ball bearing again and check all parts of this bearing with regard to excessive wear, cracks or other possible defects.

If defective beyond repair, replace old parts with new ones.

In the case of instance (b), replace the excessively worn oscillating lever No. D 26131 with a new one.

4. Noisy zig-zag sewing due to loose (worn) gears. In this case proceed as follows:

Loosen the screw No. 048100 GEB (see Fig. 61) which holds the gear and eccentric assembly No. C 26201 in the arm. Using a screw driver set into the slot of the head of No. C 26201, turn the eccentric gear bearing No. C 26201 counter-clockwise to bring the gears closer together and thus to reduce the looseness between the gears. If, by turning the aforementioned gear bearing

to its full eccentricity, there is still too much looseness between the gears, replace the worn gears with new ones.

5. The needle displacement lever No. C 26165 (Fig. 62) operates too hard (or too loose) when moved by hand during the performance of zig-zag ambroidery sewing.

In this case proceed as follows:

- a. Remove the back plate No. 26188 of the arm.
- b. Place the curved punch as shown in Figure 69 and, striking it with a hammer, remove the vertical shaft enclosure cap. No. 26481 from the inside towards the outside.
- c. Now, place the special screw driver (Fig. 63) into this opening in such a way that the teeth, which are part of the screw driver, fit into the grooves on the head of ring No. 26114 (Fig. 61). Now, turn the screw driver and loosen the ring No. 26114.
- d. With a common wrench, tighten (or loosen) the nut No. 26108 until the needle displacement lever can be operated neither too hard nor too loose.
- e. By holding the wrench steady and turning the special screw driver, tighten firmly the ring No. 26114 against the nut No. 26108 (Fig. 61).

6. The zig-zag control lever No. 26121 (Fig. 60) is too hard (or too loose) when operated by hand during zig-zag embroidery sewing

In this case proceed as follows:

- a. Remove the zig-zag stitch regulating plate No. A 26186 (Fig. 59) and the face plate No. D 26604.
- b. Disassemble the actuating rod. No D 26070 (Fig. 60) as explained on paragraph 3 pag. 64.
- c. Remove shuttle bearer removal rod pin No. 20149 at the lower end of the vertical shaft No. D 26255 by loosening the screw No. 035050 GAB (Fig. 60).
- d. Loosen the screw No. 26111 on the lever No. 26110 and remove the zig-zag control lever No. 26121.
- e. Slide the zig-zag lever movement sector No. 26106 out of the

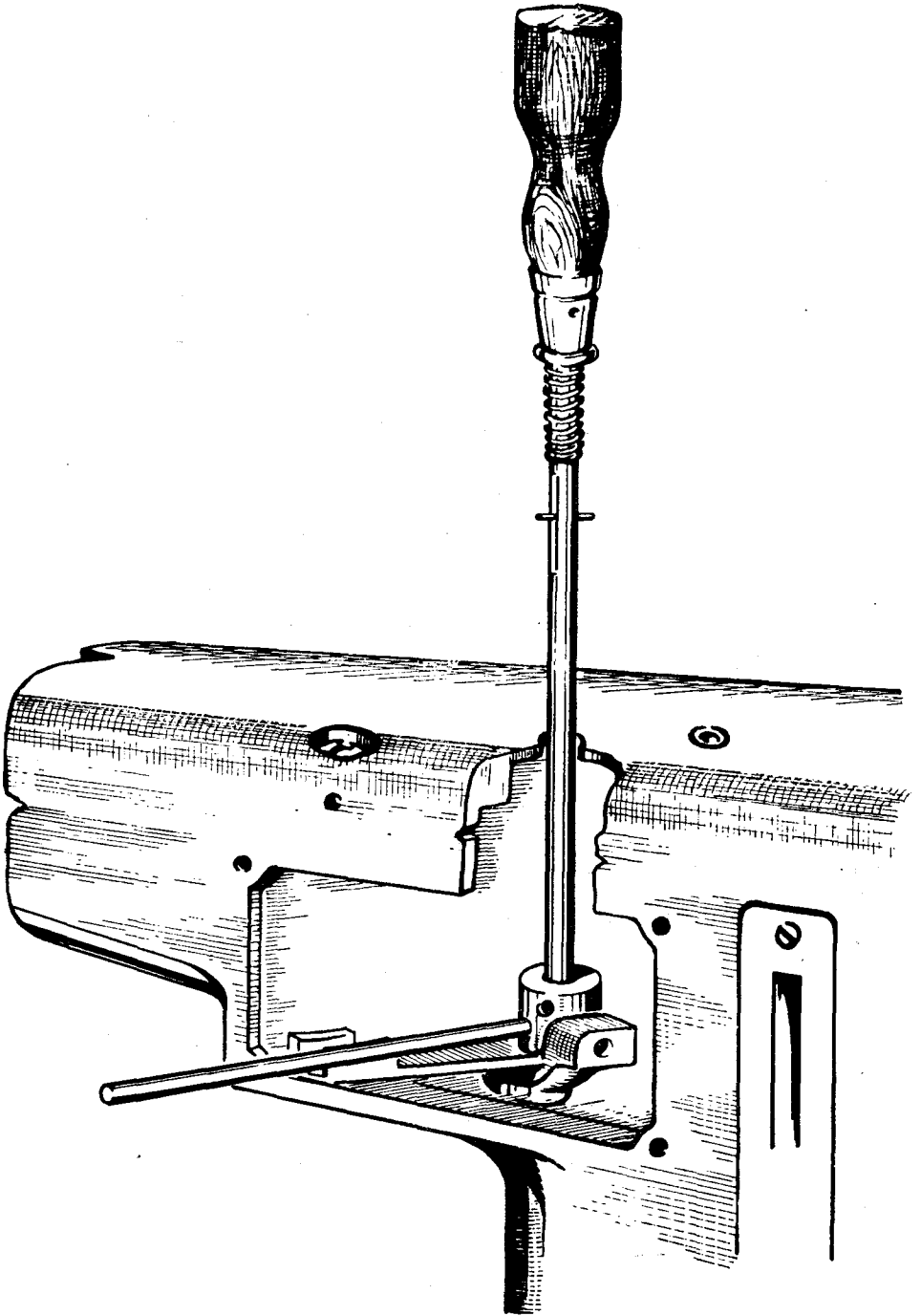

Fig. 67

oscillating lever No. D 26131 (Fig. 61) by turning the lever No. 26110 counter-clockwise. Then, slide the zig-zag lever movement runner No. 26105 (Fig. 60) out of the zig-zag regulating lever No. 26110.

f. Arranging the two connecting rods No. 26095 and No. 26250 above one another, will clear the area where the ring No. 26114 and the friction nut No. 26107 are found (Fig. 60).

g. Remove the complete oiler No. D 21260 (Fig. 66) by pushing it outwards with the curved punch of Fig. 65 from the inside of the machine.

h. Through this opening, place the special screw driver of fig. 63 on the head of the ring No. 26114, making certain, however, to have first placed the special wrench of Fig. 64 on the friction nut No. 26107 (Fig. 67).

i. Slightly loosen the ring No. 26114 with the special screw driver.

l. Loosen (or tighten), with the special perforated wrench, the friction nut No. 26107 to a degree just necessary to regulate for the proper fit of the control lever No. 26121.

m. Tighten the ring No. 26114 firmly against the nut No. 26107. Reassemble the entire group and check whether the needle bar is centered in the stitch hole of the needle plate, as explained in paragraph 1 pag. 67.

7. The machine does not sew a straight seam when the stitch control lever No. 26121 (fig. 60) is at « zero » (completely towards the left).

This can be due to two causes:

a. The stitch control lever No. 26121 is bent.

b. The chromium finished plate No. 26191 has been moved from the position it had when assembled at the factory.

In instance (a) it is necessary to replace the stitch control lever No. 26121 with a new one, after removing the zig-zag stitch regulating plate No. A 26186 (fig. 59) and after having loosened the screw No. 26111 which holds the lever No. 26121 to the lever No. 26110. (Fig. 60).

In case of instance (b) proceed as follows:

— Loosen but do not remove the two screws No. 26174 which

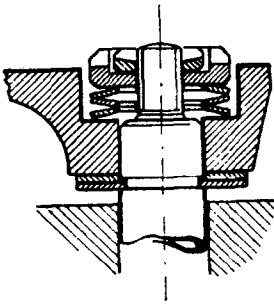

Fig. 68

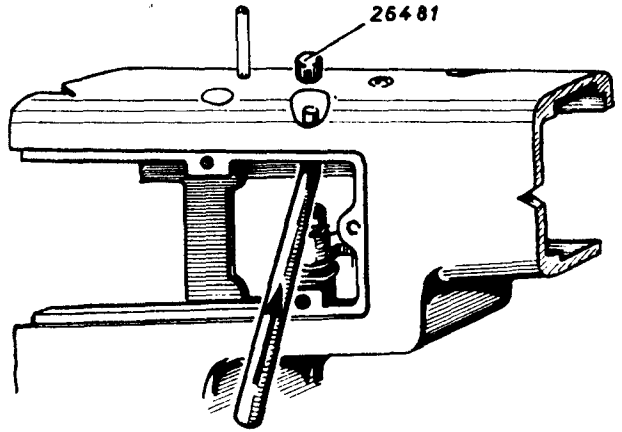

Fig. 69

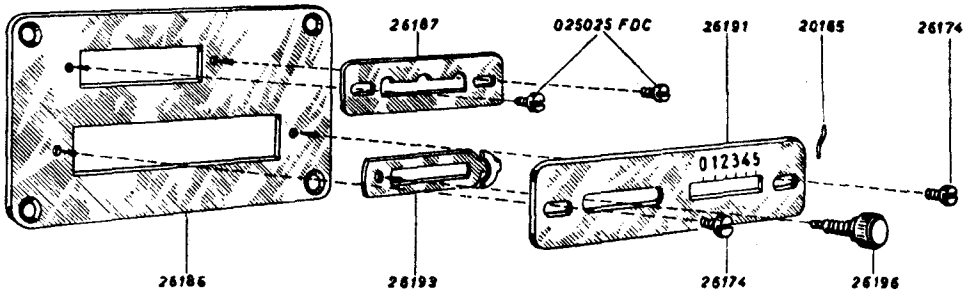

Fig. 70

hold the chromium finished plate No. 26191 (Fig. 70) to the plate No. 26186.

— Move the stitch control lever No. 26121 (fig. 60) to the left as far as it will go.

— Plate the chromium finished plate No. 26191 on the plate No. 26186 in such a way that the left edge of the right opening (with the numbers) in the plate No. 26191 be close to the zig-zag stitch control lever No. 26121 which is now in the « zero » position.

— Tighten the two screws No. 26174 (Fig. 70) firmly.



### ***Adjusting the upper group of the zig-zag Mechanism.***

The japanned zig-zag stitch regulating plate No. 26186 (Fig. 70) is assembled with several chromium finished plates No. 26187, 26193 and 26191 which are fastened to the zig-zag stitch regulating plate at the factory and should not be removed subsequently. The adjustment of all parts in the upper group of the zig-zag mechanism is done in our factory during the production of the machines. There should, therefore, be no need for adjusting these parts in the course of regular maintenance service. However, should it be necessary (as in the case of repairs) to reassemble and time the aforementioned parts, proceed as follows:

- a. Remove the zig-zag stitch regulating plate No. A 26186 (fig. 59) by loosening the four screws No. 26413 (Fig. 59).
- b. Adjust the position of the eccentric No. C 26201 (Fig. 37) as explained previously (Figs. 38 and 39).
- c. After this timing of the eccentric No. C 26201, while making certain not to move the needle displacement lever No. C 26165, turn the balance wheel and check whether the needle is at the center of the stitch hole in the needle plate.  
If the needle is not at the center of the stitch hole in the needle plate, adjust the needle bar support rod No. D 26070 as explained in paragraph 1 page 67.
- d. Replace the zig-zag stitch regulating plate No. 26186, fixing it to the arm with four screws No. 26413.

### ***The lower group of the Zig-Zag Mechanism.***

The back and forth movement is transmitted to the lower part of the machine (see Fig. 71) by means of the vertical shaft No. D 26255 (with the crank at its lower end), the race body carrier connecting rod No. D 26275, and the race body carrier connecting block No. 26281, which finally transmits this back and forth movement to the complete shuttle race assembly, the shuttle carrier and the shuttle with the bobbin case.



## TAKING CARE OF THE SEWING MACHINE MOTOR

Only little care is required to keep the sewing machine motor in order for many years of good use. The following are the most frequent causes for inferior service from the sewing machine motor, and suggestions on how to prevent and remedy them:

### **A. Motor does not run at all or runs only sluggishly.**

The above deficiency may be caused by the following circumstances:

1. *a.* The electric cords are defective, loosely connected, or not connected at all.

*b.* The electric plugs, the fuse, or the wall outlet are defective.

*c.* The motor brushes are worn, or the brush springs are excessively compressed or broken.

*d.* The rheostat (motor control) is out of order.

Check all of the above items; remedy any defects, if possible; or replace defective parts with new ones.

2. The belt between motor pulley and balance wheel of machine is too tight. Raise motor bracket until belt has just enough tension to pull the machine; tighten bracket screws.

3. Commutator of motor is dirty. Clean connector with cleaning fluid; then wipe it thoroughly dry.

### **B. Motor turns tightly.**

1. Motor shaft is bent due to:

*a.* Motor having been dropped.

b. V-belt having been forced over the motor pulley after motor was mounted in place on the machine.

Handle motor carefully to prevent above defect. Have defective motor repaired.

2. Motor bearings are gummed due to use of improper oil. Have bearings cleaned with cleaning fluid. Motor must be thoroughly dry before running it again.

*Oiling of motor:* Use only high grade sewing machine oil. Apply one or two drops of this oil into each bearing oil hole every two or three months. Do not use vegetable oils. Before oiling, clean lint from oil holes with a pin.

### ***C. Motor runs, but does not pull machine.***

1. Belt slips. This will occur if:

a. Belt between motor pulley and balance wheel is excessively stretched;

b. motor pulley is too close to balance wheel;

c. motor bracket screws, or motor fastening screws, are loose;

d. there is oil between belt and motor pulley or between belt and balance wheel.

Replace worn belt; adjust motor bracket; tighten all motor mounting screws; wipe oil thoroughly from belt, balance wheel and motor pulley.

2. Motor pulley too loose on motor shaft. Tighten screw in motor pulley.

### ***D. Motor is weak.***

Some armature wires are broken. Tampering by inexperienced persons may cause this defect. Do not use motor mounting screws longer than one quarter of an inch. Longer screws may damage the wiring in the motor.

**E. *Motor gets too hot.***

1. Belt between motor pulley and balance wheel is too tight and overloads the motor. Raise motor bracket until belt has just enough tension to pull the machine; tighten bracket screws.
2. Lack of lubrication. Lubricate both motor bearings as advised above.

**F. *Motor smokes or emits a burning smell.***

1. Motor is overloaded due to excessive belt tension. Adjust belt tension as advised above.
2. Motor is not oiled at all; wrong lubricant has been used; motor is overoiled; oil on commutator. Have motor thoroughly cleaned and oiled as suggest above.
3. Motor runs tightly due to bent shaft. Have motor repaired.

**G. *Motor runs noisily or growls. Rattling noise during sewing.***

1. Motor pulley is not in perfect alignment with balance wheel of machine. Adjust motor pulley on motor shaft until belt runs straight up to balance wheel.
2. Motor hums while machine is not sewing. Rheostat control lever gets stuck in a depressed position. Check rheostat and free the motion of the control lever.
3. Motor pulley is loose on motor shaft. Tighten screw in motor pulley.
4. Motor bracket too loose on machine, or motor too loose on motor bracket. Tighten firmly all fastening screws which hold the above parts in place.

It must be emphasized that all motors on our machines are carefully made, inspected and tested. Therefore, handle each motor with care; do not disassemble or tamper with it, unless you are thoroughly acquainted with its construction. Do not damage or scratch the motor housing; do not drop the motor.

Do not make a motor entirely useless by unnecessarily damaging it beyond repair.

### ***How to remove the Machine Head.***

1. Grip the arm of the machine head, lift it, and turn head away from you until it comes to a stop in an inclined position on the base of the portable, or on the cabinet.
2. Using a screw driver, loosen the two cabinet hinge screws No. 5032 A4B (underneath the bed of the machine) by means of which the two cabinet hinges are held in the corresponding holes of the machine bed.
3. Lift the machine head and remove it from the hinges. The mounting and fastening of the machine head on the portable, or on the cabinet, has to be done in a reversed sequence.

It is imperative to make sure that the round ends of the head hinges are *fully* inserted into the corresponding holes in the bed plate before the two screws No. 5032 A4B in the machine bed are tightened firmly.

The mounting or the removal of the machine head remains the same no matter what type of machine support (portable case or cabinet) or what kind of cabinet hinge comes into consideration.



## ALPHABETICAL INDEX

<b>A</b>	Accessories and tools . . . . .	page 4
	Adjusting the maximum rise of the feed dog teeth . . . . .	» 39
	Adjusting the movements of the various groups of parts . . . . .	» 15
	Adjusting the thread tensions . . . . .	» 12
	Adjusting the upper group of the zig-zag mechanism . . . . .	» 75
	Adjustment (BF machines) - centering the needle . . . . .	» 20
	Adjustment (BF machines) - distance between the needle and the shuttle . . . . .	» 19
	Adjustment (BF machines) - height of the needle bar . . . . .	» 17
	Adjustment (BF machines) - position of the needle eye . . . . .	» 20
	Adjustment (BU machines) - centering the needle . . . . .	» 24
	Adjustment (BU machines) - distance between the needle and the shuttle . . . . .	» 24
	Adjustment (BU machines) - height of the needle bar . . . . .	» 22
	Adjustment (BU machines) - position of the needle eye . . . . .	» 22
	Adjustment (pressure) of the presser foot . . . . .	» 46
	Adjustment of the shuttle carrier shaft . . . . .	» 28
<b>B</b>	Bobbin . . . . .	» 55
	Bobbin case . . . . .	» 55
	Bobbin case (tension) . . . . .	» 52
	Bobbin winder mechanism . . . . .	» 59
<b>C</b>	Centering the needle in BF machines . . . . .	» 20
	Centering the needle in BU machines . . . . .	» 24
	Characteristics of Necchi sewing machines . . . . .	» 14
	Cleaning (general) . . . . .	» 13
	Cleaning the shuttle race . . . . .	» 8
	Customer (instructions to be given to) . . . . .	» 5



<b>D</b>	Distance between the needle and the shuttle in BF machines . . . . .	page 19
	Distance between the needle and the shuttle in BU machines . . . . .	» 24
<b>E</b>	Elementary instructions on machine maintenance . . . . .	» 13
<b>F</b>	Feed dog . . . . .	» 37
	Feed dog and needle bar timing - general rule . . . . .	» 31
	Feed dog teeth (adjusting the maximum rise above the needle plate) - general rule . . . . .	» 39
	Feed dog - testing . . . . .	» 43
<b>G</b>	Gauge No. AC 4/75 for BF machines . . . . .	» 17
	Gauge No. AC 4/68 for BU machines . . . . .	» 26
	Gauge No. AC 4/68 - how to remove from BU machines . . . . .	» 27
	General remarks on machine maintenance . . . . .	» 14
<b>H</b>	Head - how to remove the machine head . . . . .	» 80
<b>I</b>	Insertion of the timing gauge No. AC 4/75 in BF machines . . . . .	» 17
	Insertion of the timing gauge No. AC 4/68 in BU machines . . . . .	» 26
	Instructions (elementary) on machine maintenance . . . . .	» 13
	Instructions to be given to the customer . . . . .	» 5
<b>L</b>	Lower group of the zig-zag mechanism . . . . .	» 75
	Lower thread tension . . . . .	» 52
	Lubrication . . . . .	» 13
<b>M</b>	Maintenance (elementary instructions) . . . . .	» 13
	Motor . . . . .	» 77

	Motor does not run at all or runs sluggishly . . . . .	page 77
	Motor gets too hot . . . . .	» 79
	Motor is weak . . . . .	» 78
	Motor runs, but does not pull the machine . . . . .	» 78
	Motor runs noisily and growls . . . . .	» 79
	Motor smokes or emits a burning smell . . . . .	» 79
	Motor turns tightly . . . . .	» 77
	Movements - adjusting the movements of the various groups of parts in relation to each other . . . . .	» 15
<b>N</b>	Needle . . . . .	» 44
	Needle bar . . . . .	» 44
	Needle bar - adjustment of height in BF machines . . . . .	» 17
	Needle bar - adjustment of height in BU machines . . . . .	» 22
	Needle bar and feed dog timing - general rule . . . . .	» 31
	Needle bar and shuttle timing in BF machines . . . . .	» 17
	Needle bar and shuttle timing in BU machines . . . . .	» 22
	Needle bar and zig-zag mechanism timing in BU machines - general rule . . . . .	» 34
	Needle centering in BF machines . . . . .	» 20
	Needle centering in BU machines . . . . .	» 24
	Needle - using the correct needle . . . . .	» 5
<b>O</b>	Oscillating shuttle . . . . .	» 52
<b>P</b>	Position of the needle eye in relation to the shuttle in BF machines . . . . .	» 20
	Position of the needle eye in relation to the shuttle in BU machines . . . . .	» 22
	Presser bar lever is completely raised . . . . .	» 48
	Presser bar lever is entirely down . . . . .	» 48
	Presser bar lever is partially raised . . . . .	» 48
	Presser bar positioning . . . . .	» 47

	Presser foot - bottom face rests incorrectly (not flush) on the teeth of the feed dog . . . . .	page 41
	Presser foot - height . . . . .	» 48
	Presser foot - incorrect pressure . . . . .	» 41
	Presser foot - positioning . . . . .	» 47
	Presser foot - pressure adjustment . . . . .	» 46
<b>R</b>	Rattling noise during sewing . . . . .	» 79
	Remarks (general) . . . . .	» 14
<b>S</b>	Shuttle . . . . .	» 52
	Shuttle and needle bar timing in BF machines . . . . .	» 17
	Shuttle and needle bar timing in BU machines . . . . .	» 22
	Shuttle carrier shaft adjustment . . . . .	» 28
	Shuttle race - cleaning . . . . .	» 8
	Spring (thread take-up) of the upper tension . . . . .	» 50
	Square angled bar . . . . .	» 26
	Stitch length during forward sewing is not the same as that during reverse sewing . . . . .	» 59
	Stitch regulating indicators do not move . . . . .	» 57
	Stitch regulator . . . . .	» 56
<b>T</b>	Taking care of the sewing machine motor . . . . .	» 77
	Technical characteristics of Necchi sewing machines . . . . .	» 14
	Tension adjusting . . . . .	» 12
	Tension of the bobbin case . . . . .	» 52
	Tension of the lower thread . . . . .	» 52
	Tension of the upper thread . . . . .	» 49
	Testing the feed dog . . . . .	» 43
	Thread take-up spring of the upper tension . . . . .	» 50
	Thread tensions . . . . .	» 12
	Threading of the BF and BU Mira machines . . . . .	» 6
	Threading of the BF and BU Nova machines . . . . .	» 8
	Timing . . . . .	» 15

Timing gauge No. AC 4/75 for BF machines . . . . .	page 17
Timing gauge No. AC 4/68 for BU machines . . . . .	» 26
Timing gauge No. AC 4/68 - how to remove . . . . .	» 27
Timing of feed dog and needle bar . . . . .	» 31
Timing of shuttle and needle bar in BF machines . . . . .	» 17
Timing of shuttle and needle bar in BU machines . . . . .	» 22
Timing the machine . . . . .	» 15
Timing the zig-zag mechanism and the needle bar . . . . .	» 36
Tools and necessary accessories . . . . .	» 4

<b>U</b> Upper group of the zig-zag mechanism . . . . .	» 64
Upper group of the zig-zag mechanism (adjustment) . . . . .	» 75
Upper tension - thread take-up spring . . . . .	» 50
Upper thread tension . . . . .	» 49

<b>Z</b> Zig-zag mechanism and needle bar timing . . . . .	» 34
Zig-zag mechanism - lower group . . . . .	» 75
Zig-zag mechanism - upper group . . . . .	» 64
Zig-zag mechanism - upper group (adjusting) . . . . .	» 75
Zig-zag stitch mechanism . . . . .	» 62

VITTORIO NECCHEI S.p.A.

I. G. I. LOSA - MILANO

Simb. A 40 / 114 ind. 0 - 9-54 - 5000

PRINTED IN ITALY